



Technology for Vacuum Systems

VACUUM CONTROLLER CVC 3000

Vacuum Controller



Instructions for use

**Original instructions
Keep for future use!**

This manual is only to be used and distributed in its complete and original form. It is strictly the users' responsibility to check carefully the validity of this manual with respect to his product.

Manufacturer:
VACUUBRAND GMBH + CO KG
Alfred-Zippe-Str. 4
97877 Wertheim
GERMANY

Phone:

- Head office +49 9342 808-0
- Sales +49 9342 808-5550
- Service +49 9342 808-5660

Fax: +49 9342 808-5555
E-Mail: info@vacuubrand.com
Web: www.vacuubrand.com

*Thank you for purchasing this product from **VACUUBRAND GMBH + CO KG**. You have chosen a modern and technically high quality product.*

TABLE OF CONTENT

1	Introduction	7
1.1	User information	7
1.2	About this document.	8
1.2.1	Display conventions	8
1.2.2	Symbols and icons	9
1.2.3	Handling instructions (action steps).	10
1.2.4	Abbreviations	11
1.2.5	Term definition	11
2	Safety instructions	12
2.1	Working conditions	12
2.1.1	Intended use	12
2.1.2	Improper use.	12
2.1.3	Foreseeable misuse	13
2.2	Target groups	14
2.2.1	User permissions	14
2.2.2	Personal responsibility	14
2.3	Safety precautions	15
2.3.1	Protective clothing.	15
2.3.2	Eliminate sources of danger	15
2.4	Safety and service	18
2.4.1	Meaning Health and Safety Clearance	18
2.4.2	Requirements for services	18
2.5	Environmental protection	19
3	Product description	20
3.1	Vacuum controller CVC 3000	20
3.2	Functionality	22
3.3	Operation modes	23
4	Installation and connection	24
4.1	Installation	24
4.1.1	Table top version.	24
4.1.2	Built-in version	25
4.1.3	Direct installation.	25
4.1.4	Examples of use	26
4.2	Connection	28
4.2.1	Electrical connection.	28
4.2.2	Vacuum connection	30
4.2.3	VACUU·BUS®	32

5	Operating and display elements	34
5.1	Operating elements	34
5.1.1	Selection knob	34
5.1.2	Control panel	34
5.1.3	Key combinations	35
5.2	Display and user interface	36
5.2.1	Pressure display	36
5.2.2	Display icons	37
5.2.3	Signal sounds (warning beep)	39
5.2.4	Menu display in general	40
5.3	Handling CVC 3000	41
6	Operation	43
6.1	Switch-on/-off controller	43
6.2	Select language and pressure unit	44
6.3	Mode – Operation mode	45
6.3.1	Select operation mode	45
6.3.2	Mode menu	46
6.4	Start controlling	47
6.5	Control during operation	47
6.5.1	Venting (VENT)	47
6.5.2	Change operation mode	49
6.5.3	Display graphic (curve)	51
6.5.4	Quit display graphic	52
6.6	Quick adaption during operation	53
6.6.1	Set vacuum	53
6.6.2	Motor speed (<i>only VARIO®</i>)	54
6.7	Stop control	54
7	Advanced menus and operation	55
7.1	Operation menus	55
7.1.1	Pump down	56
7.1.2	Vac control	57
7.1.3	Auto mode (only valid for VARIO® pump)	58
7.1.4	Program	59
7.1.5	VACUULAN	60
7.2	Program functions	61
7.2.1	Open/Change program	61
7.2.2	Edit program	62
7.2.3	Store program	68
7.2.4	Display during operation	69
7.2.5	Program memory	70
7.2.6	Program examples	72
7.2.7	Sample form for program	74

7.3	Configuration menu	75
7.3.1	Content selection	76
7.3.2	Submenus	77
7.4	Function menu	80
7.4.1	Content selection	81
7.4.2	Submenu Vacuubus (address assignment)	83
7.4.3	Possible address configurations	86
7.5	Differential pressure measurement	87
8	Resolving problems	88
8.1	Error display	88
8.2	Fault – Cause – Remedy	90
8.3	Controller Reset	94
8.4	Error of external components	96
9	Cleaning and maintenance	97
9.1	Cleaning	97
9.1.1	Controller	97
9.1.2	Venting valve	97
9.1.3	Internal sensor	97
9.2	Sensor readjustment	98
10	Appendix	101
10.1	Technical information	101
10.1.1	Technical data	101
10.1.2	Product comparison CVC 3000	103
10.1.3	Rating plate	104
10.1.4	Wetted parts	104
10.2	Interface commands	105
10.2.1	Pin assignment (RS232)	105
10.2.2	Read commands (CVC 2000)	106
10.2.3	Write commands (CVC 2000)	107
10.2.4	Read commands (CVC 3000)	108
10.2.5	Write commands (CVC 3000)	111
10.3	Ordering information	113
10.4	Service	115
10.5	Glossary	117
10.6	Index	118
10.7	Certifications	120
10.7.1	EC Declaration of Conformity	120
10.7.2	US/CAN Certificate	121

First steps (delivery status)

First steps on delivery status
Select language and units

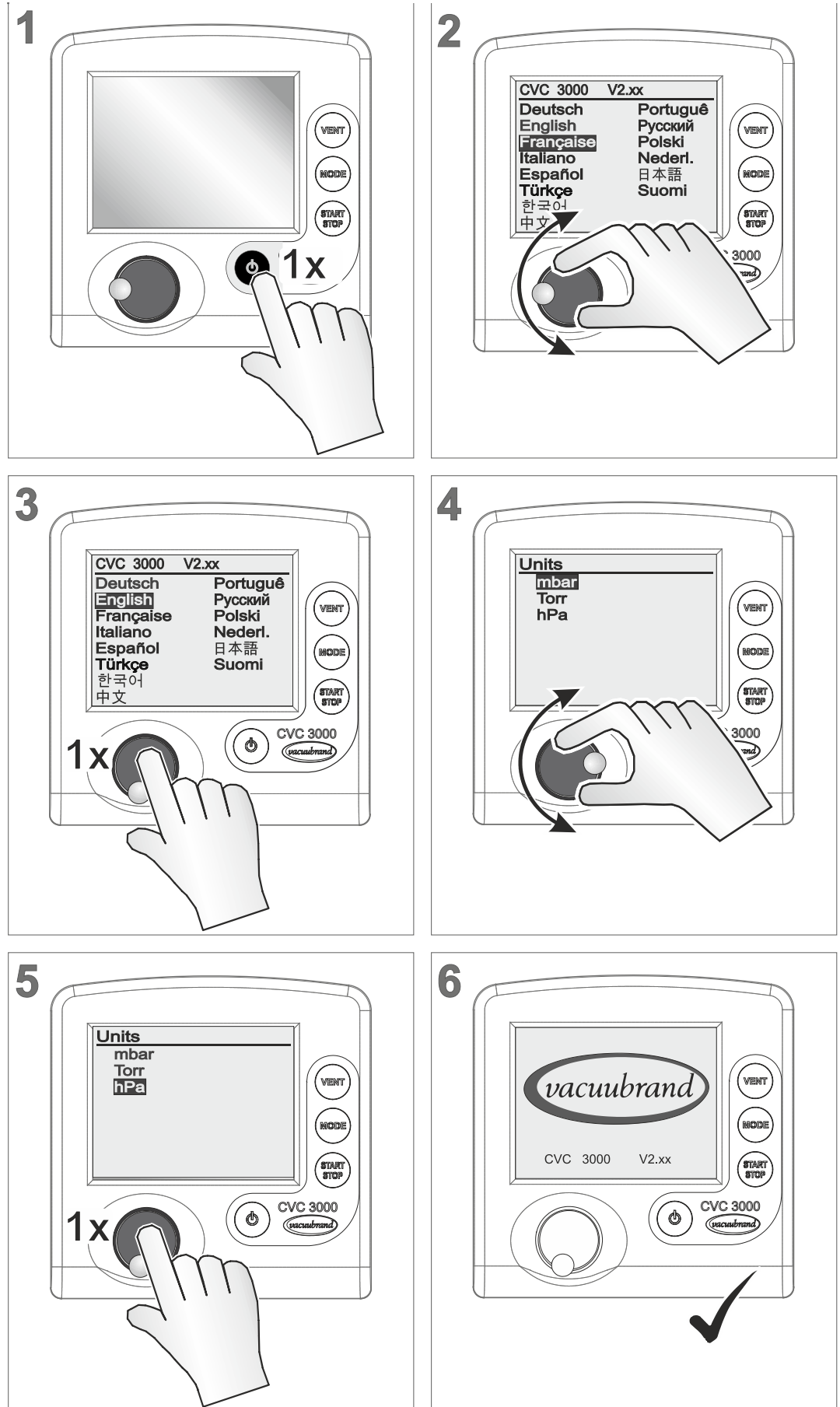

1 Introduction

This manual is part of your product. It provides important instructions for safe use of the product. Read this manual completely in order to understand proper use of your product.

1.1 User information

Safety

Instructions for use
and safety

- Read this manual thoroughly and completely before using the product.
- Keep this manual in an easily accessible location.
- Proper use of the product is essential for safe operation. Comply with all safety instructions provided!
- In addition to this manual, adhere to any relevant local accident prevention regulations and comply with industrial safety regulations.

General

General
information

- To make the text more readable in this manual, mostly the term **Controller** is used instead of **CVC 3000**.
- When giving the product to a third party also hand out these instructions for use.
- The illustrations in this manual are provided as examples. They are intended to aid in your understanding of the proper use of the product.
- **VACUUBRAND GMBH + CO KG** reserves the right to modify or change the product design and/or technical specifications at any time without advanced notice.

Copyright

Copyright ©

The content of these instructions for use is protected by copyright. Only copies for internal use are allowed, e. g., for professional training.

© **VACUUBRAND GMBH + CO KG**

Contact



- Contact us
- Please ask for replacement in case of an incomplete manual or download instructions for use on our web page: www.vacuubrand.com
 - Contact us regarding any questions about this product, if you need further information, or to provide us with feedback.
 - When contacting our Customer Service Department, please be sure to have the correct type and serial number of your product → see *Rating plate*.

1.2 About this document

1.2.1 Display conventions

Warning levels

Convention for warnings

	DANGER
	<p>Indicates an imminent hazardous situation. Disregarding the situation will result in serious and even fatal injury or death.</p> <p>⇒ Take appropriate action to avoid dangerous situation!</p>
	WARNING
	<p>Indicates a potentially hazardous situation. Disregarding the situation could result in serious, even fatal injury or massive damage to property.</p> <p>⇒ Observe instruction to avoid dangerous situation!</p>
	CAUTION
	<p>Indicates a potentially hazardous situation. Disregarding the situation could result in slight or minor injury or damage to property.</p> <p>⇒ Observe instruction to avoid dangerous situation!</p>
	CAUTION

Convention for additional notes

NOTICE
Notice for a potentially harmful situation.
 Disregarding the notice could lead to material damage.

Additional notes

IMPORTANT!

- ⇒ Information or specific use recommendation, which must be observed.
- ⇒ Important information for the proper operation.

 ⇒ Helpful tips and tricks
 ⇒ Additional information

1.2.2 Symbols and icons









This manual includes symbols and icons. Safety symbols indicate special danger in handling the product. They shall help to identify the danger directly and easier.

Safety symbols

Explanation of safety symbols

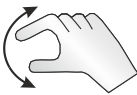
	acute toxicity – hazards to human health		
	general warning symbol		danger: electricity
	hot surface		explosive material
	general prohibition symbol		
	general mandatory sign		disconnect mains plug from outlet

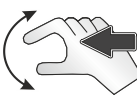
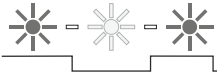
Additional icons

References		Positive example – Do! result – o. k.		Negative example – Do not!
		Refers to content of this manual.		Refers to content of other documents.
Handling or action		Press selection knob or key.		Turn selection knob
		Push and hold key		Push and turn selection knob
Signals		Flashing cycle – flashing icon indicating malfunction		
		Sound – signal or warning sound		

 ⇒ For further detailed information about icons and signals in the display see chapter **5.2.2 Display icons**.

1.2.3 Handling instructions (action steps)

Action step (single step)

Design of action steps ⇒ Do the described step.
 Result of action.

Action step (multiple steps)

1. First step,
 2. next step.
- Result of action.

Follow steps in the described order.

1.2.4 Abbreviations

Abbreviations

abs.	Absolute
ATM	Standard Atmospheric Pressure
CVC 3000	Controller
d_i (di)	Interior diameter
DN	Nominal diameter
	ATEX equipment labeling
EK	Emission condenser
EX*	Outlet
FKM	Fluoroelastomer
Gr.	Size
hh:mm:ss	Time settings in hour/minute/second
hPa	Pressure unit, hectopascal (1 hPa = 1 mbar = 0.75 Torr)
IN*	Inlet
KF	Small flange
Max	Maximum value
mbar	Pressure unit, millibar (1 mbar = 1 hPa = 0.75 Torr)
Min	Minimum value
min	Minute
PA	Polyamide
PBT	Polybutylene terephthalate
PE	Polyethylene
respon.	responsible, supervising Specialist
RMA-N°	Return Merchandise Authorization number
SW	Wrench size (tool)
Torr	Pressure unit (1 Torr = 1.33 mbar = 1.33 hPa)
VAC	Vacuum
VMS	Vacuum Management System

* labeling on top of the vacuum pump

1.2.5 Term definition

Product specific terms

...-I/O module	Interface for an external peripheral device to connect with a VACUU·BUS® capable vacuum gauge or -controller
VACUU·BUS®	Bus system by VACUUBRAND.
VACUU·CONTROL®	Web-based application as remote control for vacuum controller and gauges made by VACUUBRAND.
VACUU·LAN®	Local vacuum network for laboratories.
VARIO® control	Precise vacuum control by motorspeed control of VARIO® diaphragm pumps.

2 Safety instructions

All safety instructions must be observed by all individuals working with the product described here. The safety instructions are valid for the complete life cycle of the product.

2.1 Working conditions

Use the product only when it is in proper working condition.

2.1.1 Intended use

Intended use The **Controller CVC 3000** is a laboratory instrument, used to measure and/or control vacuum in therefore intended plants. The controller may only be used in non-explosive areas and indoors. Any other use is considered to be improper use. In that case, the safety and the protection of the system may be compromised.

Intended use also includes the following:



- observing safety information of document “**Safety Information for Vacuum Equipment**“.
- observing this manual.
- observing the manual of connected elements and to know their functioning.

2.1.2 Improper use

Using the product in contrary to its intended use could result in injury or damage to property.

Improper use includes:

- Improper use
- Using the product contrary to its intended use.
 - Operation with obvious malfunctions.

Improper use

- Controlling explosive atmosphere, which does not compare to the ATEX approval of the **CVC 3000** → *see rating plate*.
- Unauthorized modifications and the use of accessories and spare parts that are not recommended by the manufacturer.
- Use in mining.

2.1.3 Foreseeable misuse



Additionally to improper use there are types of use and dealing with the product, which are generally prohibited:

Reasonably
foreseeable
misuse

- The control of media which is liquid, hot, instable, or explosive.
- Installation and operation in explosive environments.
- To switch on/-off by foot or with unsuitable tool.
- To operate the controller with sharp stylus or objects.
- To put the controller completely into vacuum.
- To immerse the controller into liquid or to blast it with steam.
- To use the remote control **VACUU·CONTROL**[®] with CVC 3000 without knowledge of the connected vacuum system.

2.2 Target groups

IMPORTANT!

Ensure that the controller is only operated by authorized and skilled personnel.

Users need to have the corresponding skills and qualifications for doing the job listed in the table *User permissions*.

2.2.1 User permissions

This manual must be read, understood and complied with by the person performing one of the following tasks:

Responsibility
Assignment Matrix

Task (Job)	User	Specialist	Supervising Specialist
Installation and assembly		X	X
Commissioning		X	X
Operation	X	X	X
Readjust vacuum sensor		X	X
Error report	X	X	X
Troubleshooting		X	X
Update		X	X
Cleaning, simple	X	X	X
Clean vacuum sensor		X	X
Decontamination			X*
Repair order			X

* or order the decontamination by a qualified service provider.

2.2.2 Personal responsibility

Safe work

Personal safety has top priority. Processes which create a potentially hazardous situation are not allowed.

Always be conscious of safety, and work in a safe manner. Observe the owners' directives at work, the national accident prevention regulations and occupational safety provisions.

⇒ Use the controller only if you have understood its function and this manual.

2.3 Safety precautions

Quality standards and safety

Products of **VACUUBRAND GMBH + CO KG** are subject to high quality tests with goals for safety and operation. Prior to delivery each product has been tested thoroughly.

2.3.1 Protective clothing

Protective clothing

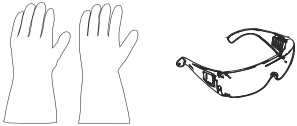

No special protective clothing is required when working with the controller. Observe the owners regulation for workplaces.

Only for cleaning the controller we recommend to wear protective gloves, protective clothing and safety goggles.

IMPORTANT!

- ⇒ Be sure to observe the local requirements for decontamination.
- ⇒ Wear your personal protective equipment when handling chemical materials.

2.3.2 Eliminate sources of danger

	DANGER
	<p>Explosion hazard for critical processes. Depending on the process explosive mixtures can develop.</p> <p>⇒ Never operate critical processes unattended!</p>

Explosion danger for critical processes

Depending on the running process, explosive mixtures can form in plants or other hazardous situations could result!

IMPORTANT!

Malfunctions which may affect safety must be eliminated immediately.

- ⇒ Do not work with damaged components.
- ⇒ Replace defective parts immediately, e. g., broken cable or faulty plug-connection.

Sources of error during connection

NOTICE

Measuring error due to an obstructed vacuum line.

⇒ Prevent overpressure > 1060 mbar (> 795 Torr) in the piping system.

Condensate Condensate can falsify the measurement. Position the vacuum hose in such a way that condensate cannot flow towards the controller and its vacuum sensor. No liquid should accumulate inside the vacuum hose.

⇒ Install vacuum hoses in such a way that condensate cannot flow into the controller.

Particles, liquids, dust Particles, liquids or dust may not enter the controller.

⇒ Install a separator or filter at the intake of the system. Appropriate filters are for example chemically resistant, and resistant to clogging.

Risks due to residual energy

Residual energy After switching off the controller and disconnecting it from mains, risk of residual energy could still prevail at the power supply adapter.

⇒ Repairs may only be performed by qualified personnel, e. g., service technician.

Option **CVC 3000 in combination with VACUU·CONTROL®**

VACUU·CONTROL® is a remote control for the controller. It is available as an accessory.

With this accessory a vacuum system can be operated simultaneously by controller or via **VACUU·CONTROL®**. Remote control is able to operate from several end devices, e. g., smart phone, tablet, or computer.

When using remote control please regard the following:

- ⇒ Coordinate planned projects with colleagues sharing the equipment.
- ⇒ If necessary inform colleagues that you plan to use the remote control.
- ⇒ Avoid different, parallel settings.

Installation and explosive environment

Installation and operation in areas where explosive atmospheres can occur is not allowed.

ATEX marking

ATEX category



Controllers which are labeled with  have an ATEX approval 3 G; i. e. flammable substances as mixture with air: pumped gas or vapor.

- ⇒ Use the controller only when it is in proper working condition.

ATEX approval¹ is only valid for the internal, wetted parts area (vacuum sensor), not for the environment of the controller.

ATEX category and peripherals

The ATEX category of the controller is dependent on the connected peripheral devices. Peripherals and connected devices to the controller need to have the same or must have a higher ATEX approval. Without concordant categorization of peripherals, the specified category of the VACUUBRAND equipment loses its validity.

Avoid ignition sources

The use of gas ballast or the operation of venting valves is only permitted if thereby explosive atmospheres normally do not occur in the interior of the equipment or, if they do occur, are likely to do so only infrequently and for a short period.

- ⇒ If necessary vent with inert gas.

For more and detailed information about ATEX approval visit our website: www.vacuubrand.com/Information-ATEX

¹ -> compare to rating plate

2.4 Safety and service

Obligations for
service jobs

Safety regulations that apply to your work environment also apply to persons who perform service works, especially in the handling of hazardous materials.

2.4.1 Meaning Health and Safety Clearance

Products which are potentially hazardous may only be returned when all dangerous contaminations are removed.

IMPORTANT!

- ⇒ Observe the requirements for services.
- ⇒ Observe the *Notes on return to the factory* listed on the form Health and Safety Clearance.
- ⇒ Protect the service personnel from hazardous substances.
- ⇒ Confirm harmlessness with your signature.



⇒ The form [Health and Safety Clearance](#) is also available on our website.

2.4.2 Requirements for services

Fulfill the following conditions

1. Clean your product thoroughly and if necessary decontaminate it professionally.

IMPORTANT!

For all service works hazardous substances need to be excluded.

2. Fill in the form *Health and Safety Clearance* thoroughly and completely.
3. Contact your local supplier or our service department.
4. Request a **RMA-N°** for your **service order**.

5. Before returning the product, please send the signed *Health and Safety Clearance* form to your local supplier or our service department.

IMPORTANT!

For all service works the safety clearance needs to be proofed and confirmed.

⇒ Did your product get in touch with hazardous substances?
Please wait for the release of reshipment.

6. Send in your product including:

- RMA-N°,
- Service order (e. g., repair),
- Form *Health and Safety Clearance*,
- Short description (e.g., malfunction, working environment, media).



Any more questions? We will help you:

Phone: +49 9342 808-5660

Fax: +49 9342 808-5555

service@vacuubrand.com

2.5 Environmental protection

NOTICE

Risk of environmental damage due to incorrect disposal of the controller.

- ⇒ Do not dispose your product in household waste!
Electronic components are subject to hazardous waste treatment and must only be disposed of by certified specialists.
- ⇒ Observe the national regulations for safe disposal and environmental protection.
- ⇒ Receive detailed information about respective regulations from your competent administrative authority.



3 Product description

Goods arrival

Check incoming goods

Check the shipment for transport damage and completeness.
⇒ Report any transit damage immediately to the supplier.

NOTICE

Condensate can damage the controller.

A large temperature difference between storage location and installation location can cause condensation.

⇒ Let the product acclimatize for 3–4 hours.

Included materials

Scope of supply

Controller	
Vacuum controller CVC 3000	see <i>Ordering information on page 113</i>
Power supply unit 30W 24V; including interchangeable mains plugs	612090
Instructions for use	999151
Safety Information for Vacuum Equipment	999254
Origin packaging	-----

3.1 Vacuum controller CVC 3000

The controller is designed for applications requiring controlled vacuum.

The controller has a two-point control mode to switch an in-line isolation valve.

The controller is freely programmable. Up to 10 programs can be stored in the controller memory. Each program also offers up to 10 program steps (time/pressure) plus control functions, such as: venting, pump down and ramp function.

The controller enables the measurement of relative pressure with regard to a reference sensor (VSK 3000).

Front

Front panel

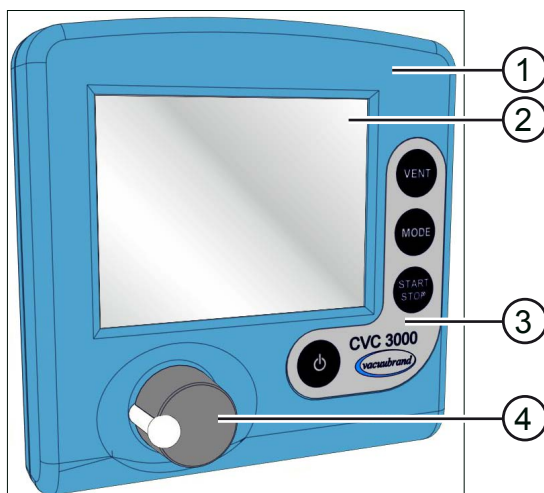

Meaning

- | | |
|---|--------------------------------------|
| 1 | Chemically resistant plastic housing |
| 2 | LC display |
| 3 | Control panel and product name |
| 4 | Selection knob |

Rear side

Rear side

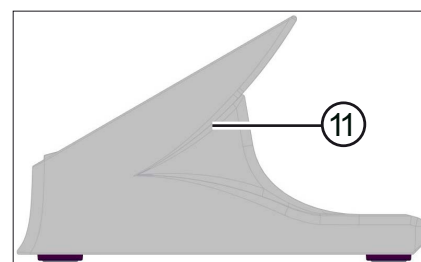
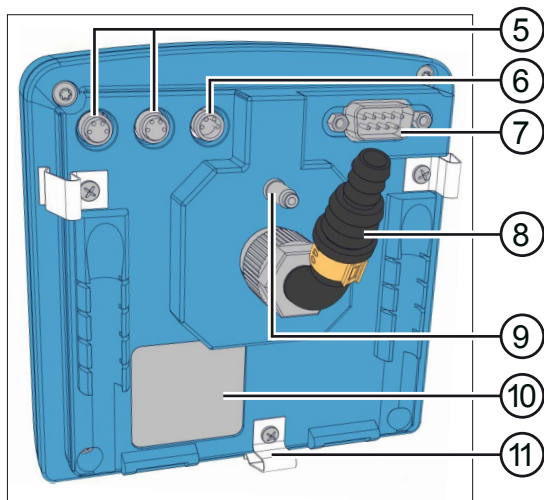

Meaning

- | | |
|----|--|
| 5 | Ports for VACUU-BUS® components |
| 6 | Mains connection
▶ power supply unit
▶ VARIO® diaphragm pump or
▶ pumping system |
| 7 | Serial port RS 232 C (Sub-D) |
| 8 | Hose nozzle, vacuum connection |
| 9 | Venting tube, connection for external venting, e. g., inert gas |
| 10 | Rating plate |
| 11 | Spring clip as fixation for built-in version
or
plastic foot for table top version |

3.2 Functionality

Functionality The controller manages vacuum processes by controlling vacuum pumps, in-line isolation- and/or air admittance valves. It controls process vacuum, cooling water and venting to demand.



Valves and/or vacuum pumps are necessary to operate the controller.

Without those components the controller can only be used as vacuum measurement device.

Specification

Specification and features

- Ceramic diaphragm vacuum sensor¹ and venting valve are already integrated into the controller.
- The ceramic vacuum sensor is chemically highly resistant, measures accurately and is gas-type independent.
- External valves, level sensors and vacuum sensors can be connected directly by **VACUU-BUS**[®] system, e. g., vacuum-, in-line isolation-, cooling- and air admittance valves as well as level sensors and emission condenser **Peltronic**[®].
- While booting the controller checks for current configuration of connected components.
- Connected components are detected automatically due to **VACUU-BUS**[®] and controlled by the controller until the controller is switched off. Safety sensitive components stay configured and are monitored again after controller restart.
- Operating elements are the selection knob, buttons on the control panel and full text menus on the display.
- Port RS 232 can also be used for connecting the remote control **VACUU-CONTROL**[®]. The controller can be operated by one or several end devices, e.g., smartphone, tablet, computer.



¹ -> excluded for package fine vacuum control with VSP 3000.

3.3 Operation modes

Up to 5 different operation modes are selectable at the controller. Specific modifications can be realized by individual mode menus.

Selectable operation modes

- | | |
|------------|--|
| Standard | <ul style="list-style-type: none">▪ Pump down▪ Vac control▪ Program |
| Optionally | <ul style="list-style-type: none">▪ Auto mode▪ VACUULAN |

For more information about individual operation modes
→ see chapter *6.3.2 Mode menu*

4 Installation and connection

The controller is designed for installation directly at the workplace.



⇒ Observe all specifications for installation, connection and operation according to technical data,
→ see *chapter 10.1.1 Technical data*.

⇒ Also observe rating plate data.

Installation conditions

Consider installation conditions

- The controller has acclimatized.
- Ambient conditions are observed and are within the limitation of use.

Limitation of use		(US)
Ambient temperature	10–40 °C	50–104°F
Altitude, max.	3000 m above sea level	9840 ft above sea level
Relative humidity	30–85 %, non condensing	
Degree of protection (controller front)	IP 20 (IP 42)	
Avoid condensation or contamination by dust, liquids or corrosive gases.		

4.1 Installation

4.1.1 Table top version



The table top or bench-top type controller can be installed and connected directly on top of the work bench or on laboratory table. The table top version is supplied with a hose nozzle. The hose nozzle should be positioned in a way that the connected vacuum hose cannot kink.

4.1.2 Built-in version



The CVC 3000 can be used as built-in version fixed with spring clips; e. g., as front controller of a **VARIO**[®] pump, built into a cable duct cover or into the cut-out of a switch cabinet.

Cut-out for switch cabinet or cable duct cover

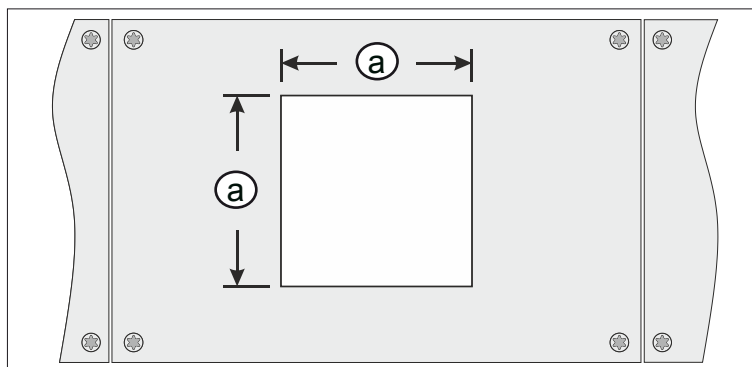

Thickness		Size (a) for cut-out	
1 mm	0.04 in.	111,5 mm x 111,5 mm	4.39 in. x 4.39 in.
2 mm	0.08 in.	112 mm x 112 mm	4.41 in. x 4.41 in.
3 mm	0.12 in.	112,5 mm x 112,5 mm	4.43 in. x 4.43 in.

Depending on the wall thickness the cut-out size needs to be fitted.

4.1.3 Direct installation

The controller can be mounted directly at the vacuum vessel using a clamping ring

→ see also example *CVC 3000 directly mounted* on page 27.

4.1.4 Examples of use

→ Example
VARIO® pump with
CVC 3000 and
rotary evaporator

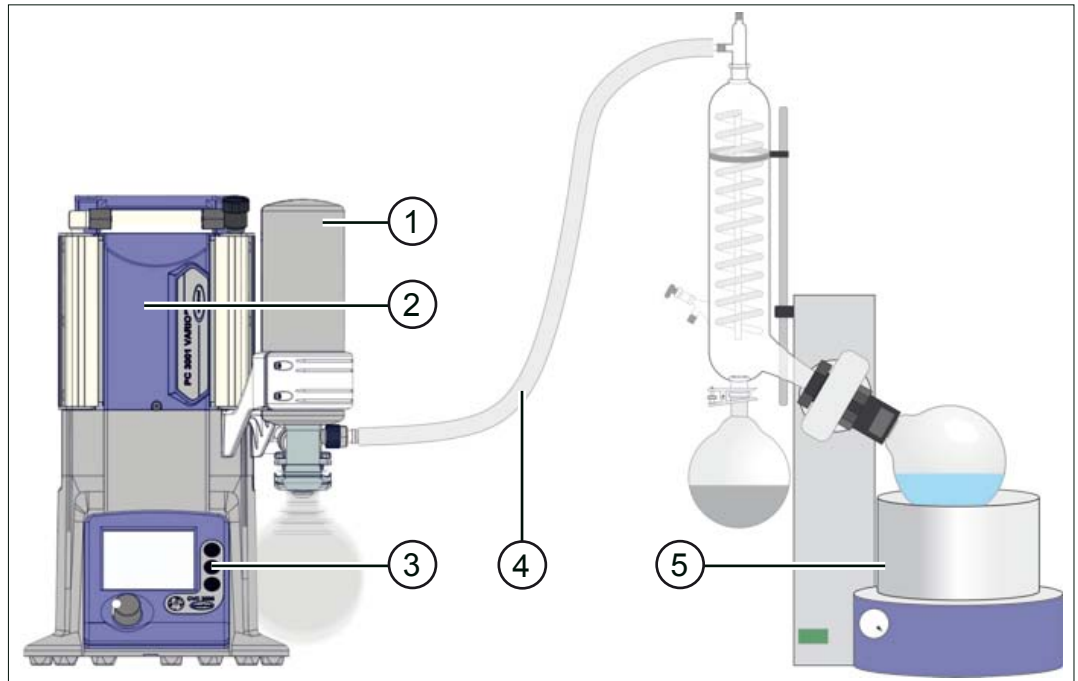

- 1 Emission condenser with round flask
- 2 **VARIO®** pump (PC 3001 **VARIO®**pro)
- 3 Controller CVC 3000, built-in version
- 4 Vacuum hose
- 5 Rotary evaporator

→ Example
CVC 3000 build-up
with cabinet dryer

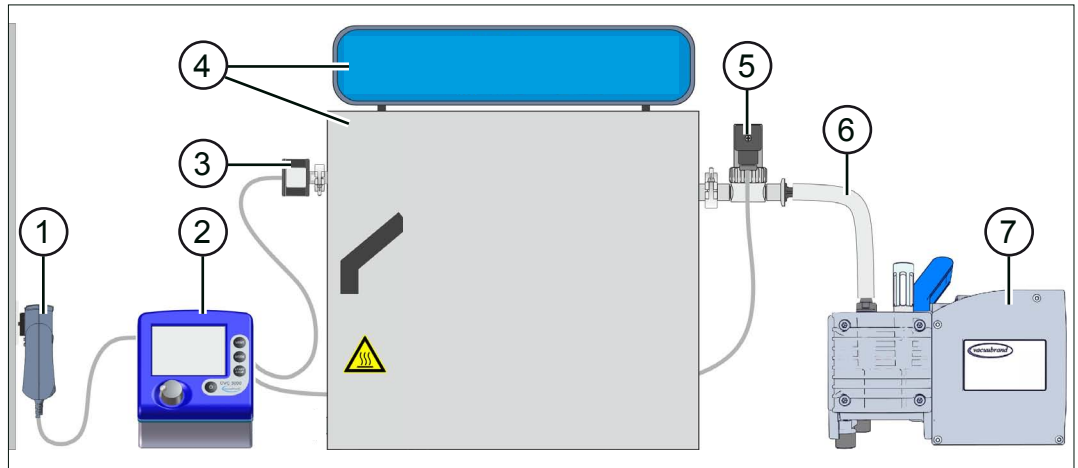

- 1 Wall power supply
- 2 Controller CVC 3000, table top version
- 3 Vacuum sensor (VSK)
- 4 Cabinet dryer with control unit on top
- 5 Vacuum valve
- 6 Vacuum hose
- 7 Diaphragm pump, vacuum pump

→ Example
CVC 3000 directly
mounted

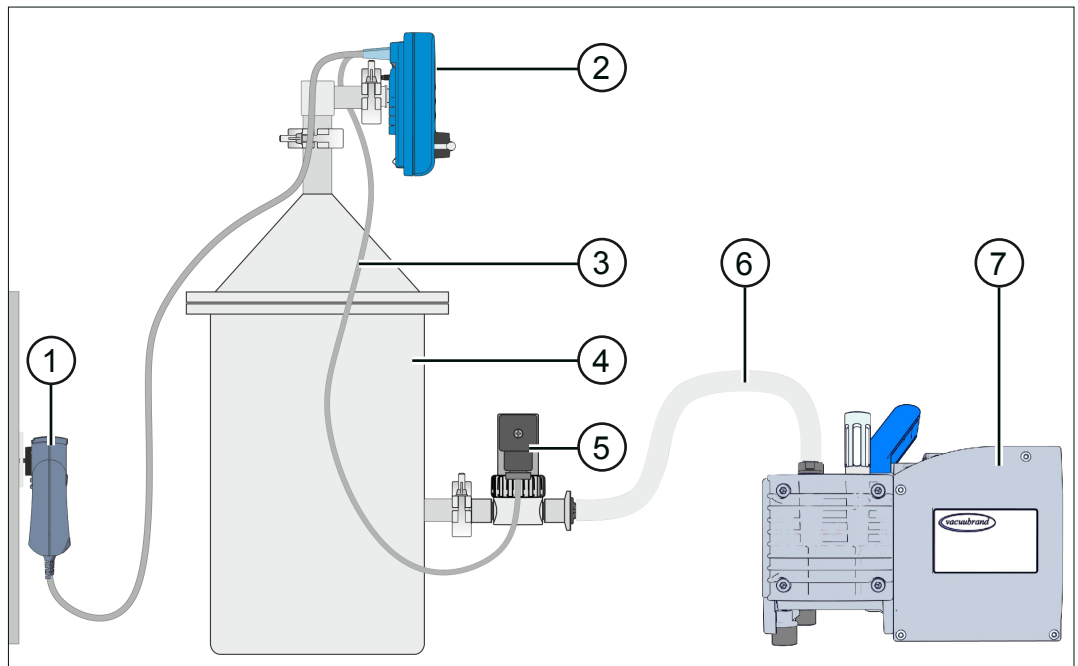

- | | |
|---|---------------------------------------|
| 1 | Wall power supply |
| 2 | Controller CVC 3000, directly mounted |
| 3 | VACUU-BUS® cable |
| 4 | Vacuum vessel, recipient |
| 5 | Vacuum valve |
| 6 | Vacuum hose |
| 7 | Diaphragm pump, vacuum pump |



⇒ Install the controller as close as possible to the process in order to optimize vacuum control.

4.2 Connection

4.2.1 Electrical connection

Wall power supply kit*

Power supply kit
for CVC 3000



** short-circuit-proof multi-voltage power supply with integrated overload protection and changeable mains plugs.*

Prepare wall power supply plug

Prepare connection

1. Take the wall power supply kit out of the packaging.
2. Select the mains plug that fits to your mains socket.
3. Connect the mains plug to the metal contacts of the wall power supply plug.
4. Slide the mains plug until it locks.

Remove mains plug

Remove mains plug

1. Press the locking knob on top of the wall power supply plug.
2. Remove the mains plug.
 - Another mains plug can be fixed.

Connect power supply to the controller

⇒ Plug female connection of the power supply cable into mains connection of the controller.

Mains connection on the rear side

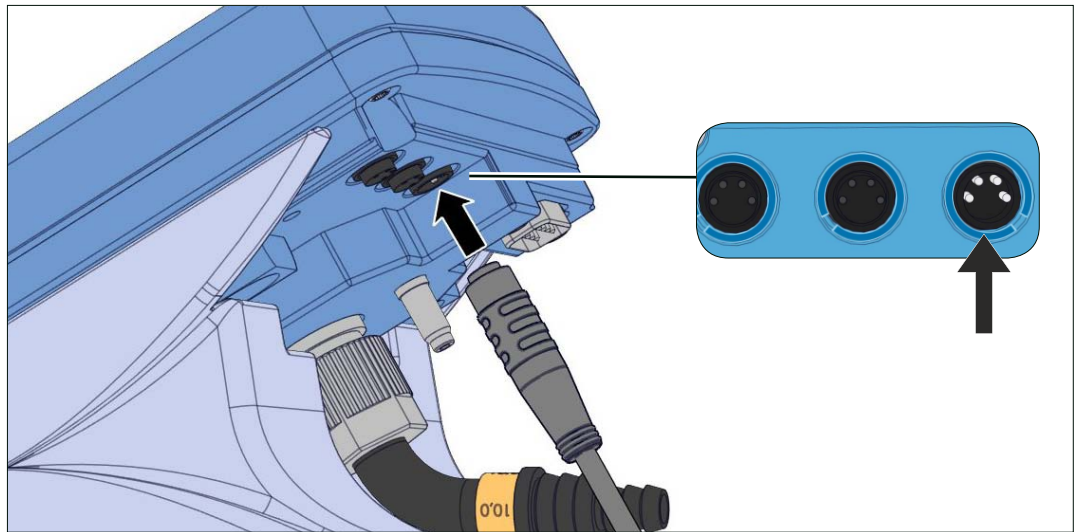

Ports with guide groove

Consider new connection design:

For easy connection, the CVC 3000 of the newest series have a guide groove on the rear side for each port.

For connection insert the nose of the round plug into the guide groove.

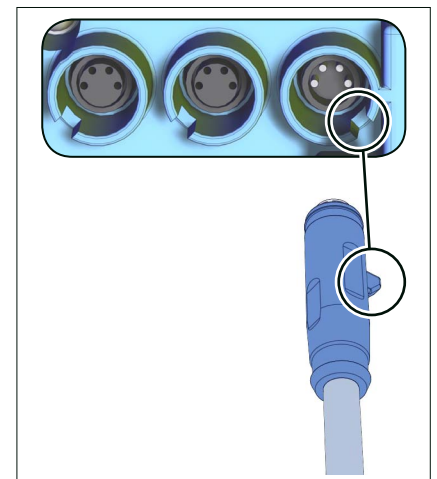

IMPORTANT!

⇒ Please install the power supply line in such a way, that no damage be caused to the cable due to sharp edges, chemicals or hot surfaces.

Connect to mains

⇒ Plug the wall power supply into the mains socket.

- ☑ Green LED at wall power supply plug glows.

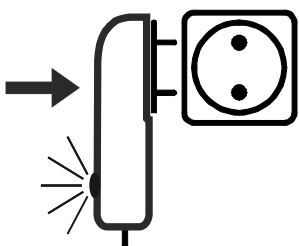

4.2.2 Vacuum connection

NOTICE

Flexible vacuum hoses can contract because of evacuation.

- ⇒ Fix vacuum hose at the connections.
- ⇒ Fix connected components.
- ⇒ Measure and trim the vacuum hose to a length that cares for the maximum shrinkage.

Possible damages to parts which are in contact with process media.

Residuals of aggressive or condensing media can cause damages to the controller or its inner parts.

- ⇒ Prevent that damaging process media can get into the controller.

Filters will compromise measurement and control.

Connect vacuum line

- ⇒ Connect the vacuum line gas-tight to the vacuum port of the controller;
→ see also *Connection examples on page 31*.

IMPORTANT!

- ⇒ Only use a vacuum hose that is sufficient for the purpose and which provides enough stability.
- ⇒ Use hose tubes as short as possible.
- ⇒ Maximum admissible pressure at vacuum sensor:
1,5 bar/ 750 Torr (absolute).
- ⇒ Observe the maximum measuring limit of the controller, approximately 1060 mbar (795 Torr).

Connection examples

Depending on design and installation the controller provides several options for connection to the vacuum system.

Table top version

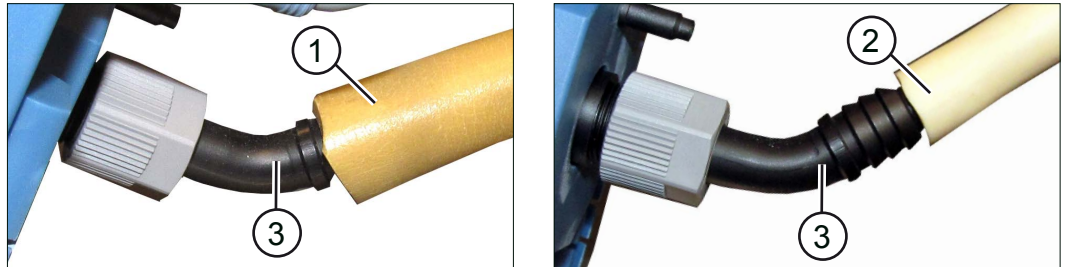

- Flexible caoutchouc hose (1) or (2), directly plugged on the hose nozzle (3).

Direct installation

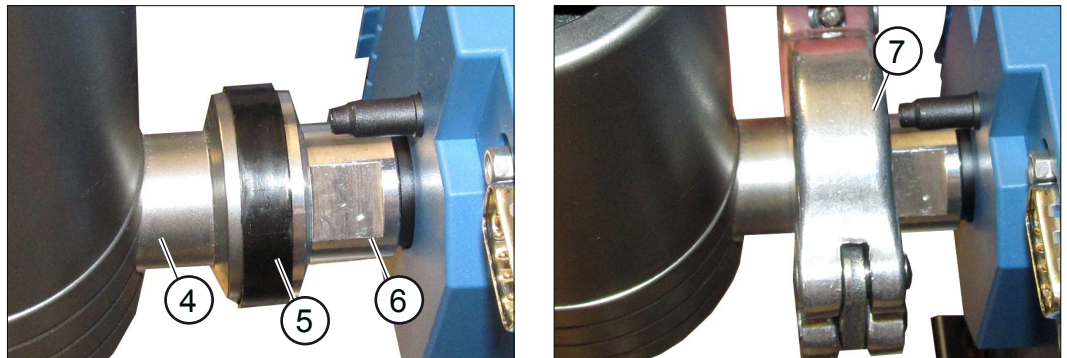

- **Flange connection (4)** at vacuum chamber with sealing ring (5) and small flange (6) screwed to CVC 3000 fixed with clamping ring (7).

Built-in version
(front mounting)

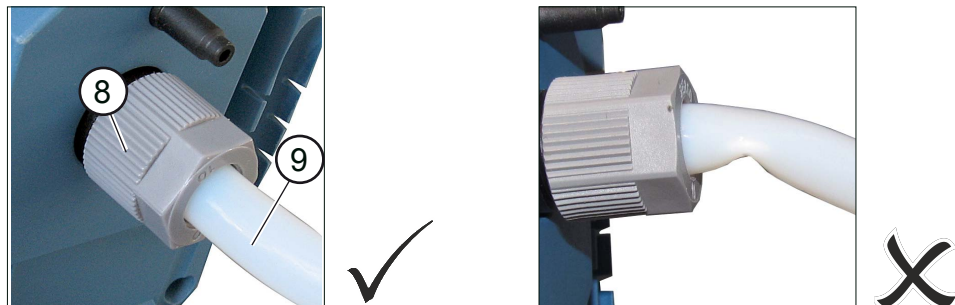

- Vacuum hose made of PTFE (9) – plugged on hose nipple, fixed with union nut (8).

IMPORTANT!

With built-in controller the vacuum port is not visible. The vacuum hose may not be kinked.

- ⇒ Make sure there is sufficient space inside the housing, or
- ⇒ use a stable, curved hose nozzle for connection.

4.2.3 VACUU-BUS®

Meaning and functioning

VACUU-BUS® is a system for communication to peripheral accessories which can be directly connected to the controller. These accessory components are self-configuring by switching on the controller. All **VACUU-BUS®** components are compatible to the controller.

Two ports on the rear of the controller are for connection of **VACUU-BUS®** components. These plug-and-socket connections and Y adapters make it possible to connect up to 32 accessory components.

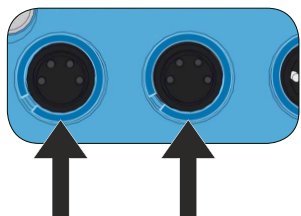

VACUU-BUS® principle

→ Example
Principal sketch

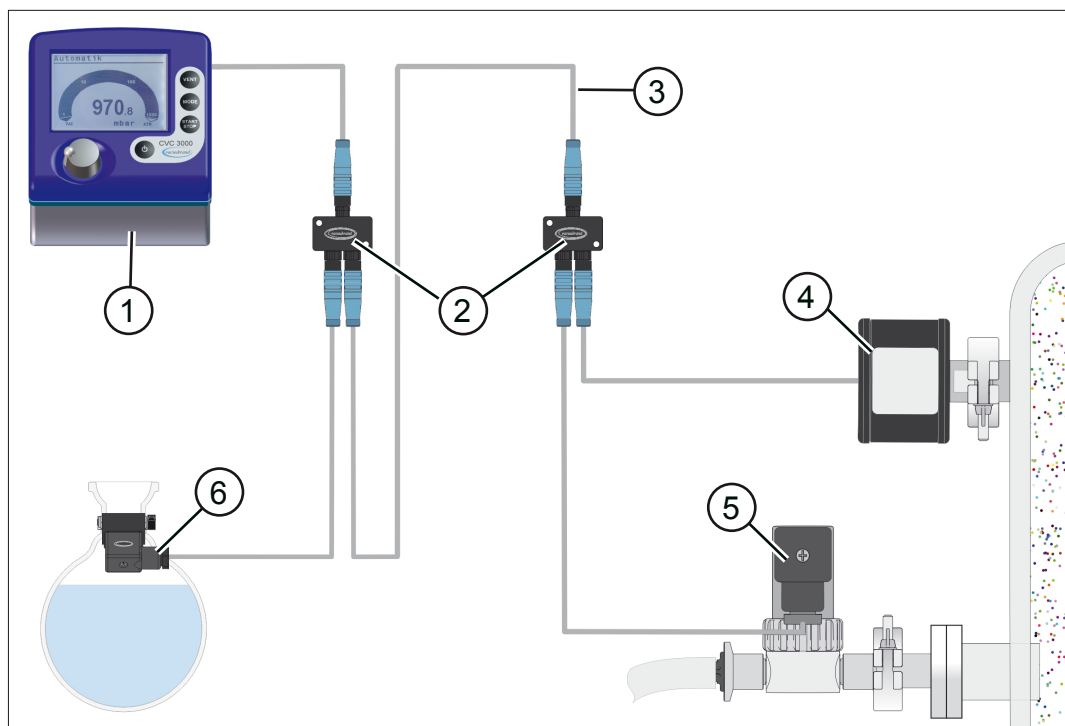

VACUU-BUS®
componentc

- | | |
|-------------------|--------------------------------|
| 1 CVC 3000 | 4 Vacuum sensor VSK |
| 2 Y adapter | 5 Vacuum valve (In-line valve) |
| 3 Extension cable | 6 Level sensor |

IMPORTANT!

⇒ When connecting multiple, identical **VACUU-BUS®** components, e. g., 3 external vacuum sensors VSK, those first need to be assigned different addresses, in order to avoid communication faults. → see *chapter 7.4.2 Submenu Vacuubus (address assignment)*.

VACUU·BUS® components

VACUU·BUS®
accessories
(Option)

Vacuum sensor	VSK 3000	636657
	VSP 3000	636163
Vacuum gauge	VACUU·VIEW	683220
	VACUU·VIEW extended	683210
Vacuum valve <i>(In-line valve)</i>	VV-B 6	674290
	VV-B 6C	674291
	VV-B 15C, KF 16	674210
	VV-B 15C, KF 25	674215
Coolant valve	VKW-B	674220
Air admittance valve	VBM-B	674217
Vacuum module for switching vacuum pump	VMS-B	676030
...-I/O module	Digital... IN: 5-75 VDC / OUT: 60 VDC (2,5 A) IN: 5-50 VAC / OUT: 40 VAC (2,5 A)	636228
	Analog... IN: 0-10 V / OUT: 0-10 V	636229
	Analog... IN: 4-20 mA / OUT: 0-10 V	635425
Level sensor	500 ml round bottom flask	699908
Extension cable	VACUU·BUS® 2 m (6.5 ft)	612552
	VACUU·BUS® 10 m (32.8 ft)	
Y adapter	VACUU·BUS®	636656

5 Operating and display elements

5.1 Operating elements



The operating elements are located on the controller front.
controller figure → see chapter 3.1 *Vacuum controller CVC 3000*

5.1.1 Selection knob

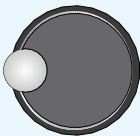
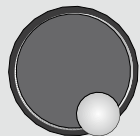
The selection knob of the controller is a combination of rotary knob and push-button.

	Selection knob	Meaning
Press selection knob		Press – Selection knob = <ul style="list-style-type: none"> ▶ Call up menu or function. ▶ Exit menu or function. ▶ Confirm and store setting or selection. ▶ Step to next menu, function or content. ▶ Call up Configuration menu while booting.
Turn selection knob		Turn – Selection knob = <ul style="list-style-type: none"> ▶ Select menu, navigation function. ▶ Value setting – increase/decrease. ▶ Adapt set vacuum (in mode Vac control).

5.1.2 Control panel

	Key	Meaning
Control panel keys		On/Off <ul style="list-style-type: none"> ▶ Switch on/off controller.
		Start/Stop <ul style="list-style-type: none"> ▶ Start/stop vacuum control. ▶ Confirm completed program when clock icon blinks. ▶ Confirm error and status indications.
		VENT – system venting; <ul style="list-style-type: none"> ▶ Keystroke < 2 sec = momentarily venting, control continues. ▶ Keystroke > 2 sec = venting to atmospheric pressure (max. 1050 mbar/787 Torr), control stops. ▶ Keystroke while venting = venting stops.

Control panel keys

MODE *Mode* – Select operation mode

- ▶ With stopped operation: Mode menu for selecting the operation mode.

Mode – Change function/mode

- ▶ During running operation: To switch from *Pump down* to *Vac control* and further to *Auto mode*.
- ▶ During running operation: To switch between *Auto mode* and *Vac control*.

5.1.3 Key combinations





Menus and functions that are not intended for everyday use, can only be accessed through key combinations.

NOTICE

Wrong key combinations can lead to faulty settings.

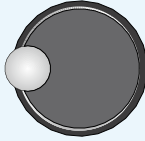
⇒ First push and hold the key which must be hold and pressed, only then push the combination key shortly.

Key combinations
(key shortcuts)

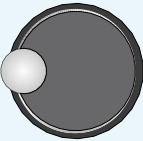
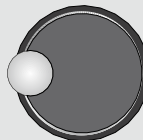
Combination	Meaning
 + 	Press and hold <i>Selection knob</i> + Press <i>On/Off</i> = Only when the controller is switched off <ul style="list-style-type: none"> ▶ Call up menu <i>Language selection</i> ▶ Call up menu <i>Pressure unit</i>
 + 	Press and hold <i>VENT</i> + Press <i>On/Off</i> = <ul style="list-style-type: none"> ▶ Call up menu <i>Function</i>
 + 	Press and hold <i>Mode</i> + press <i>Selection knob</i> = Only in <i>Function</i> menu <ul style="list-style-type: none"> ▶ Enable Vacuubus address assignment (frame marking). ▶ Confirm parameter transfer of selection <i>Vario init</i>.
	Press and hold <i>Selection knob</i> + turn it = <ul style="list-style-type: none"> ▶ Quick adaption set vacuum. (in mode <i>Vac control</i>) Only in combination with VARIO® <ul style="list-style-type: none"> ▶ Quick adaption motor speed high/low (in mode <i>Pump down</i>)

5.2 Display and user interface

After booting the pressure display appears, including **Bar graphic** and preset operation mode.

5.2.1 Pressure display

→ Example
Display after
switching on
CVC 3000

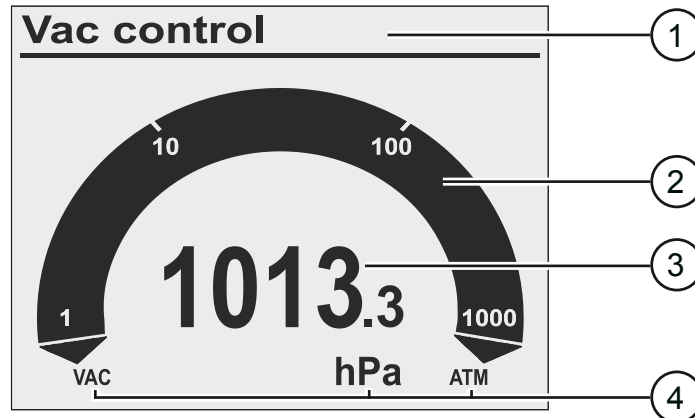

Meaning

1 Title bar (or status bar)	<ul style="list-style-type: none"> ▶ Operation mode - <i>Mode</i> ▶ Pump down ▶ Vac control ▶ Auto mode ▶ Program ▶ VACUULAN ▶ Process time ▶ hh:mm:ss (only displayed with running process)
2 Bar graphic	▶ Graphical display of actual pressure
3 Numerical value	▶ Actual pressure = digital pressure display
4 VAC	▶ Vacuum
mbar	▶ Pressure unit according to pre-setting (mbar, Torr, hPa)
ATM	▶ Atmospheric pressure

5.2.2 Display icons

When vacuum control has started additional icons appear on the display.





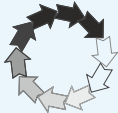

When starting operation

Display symbols during operation

Icon	Meaning
	Vacuum control is running (animation)
00:00:00	Process time; runtime vacuum control (hh:mm:ss)

Active component

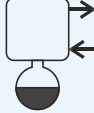
Icons for active components







Icon	Meaning
	Pump is running; in combination with percentage sign = motor speed (only for VARIO systems)
	Venting* valve is active, i. e. open (VENT); Flashing cycle: continuous venting switched on.
	Coolant valve switched on, open
	In-line valve switched on, open
	Emission condenser (Peltronic) connected
	Level sensor activated (only when level sensor is connected)

* also named air admittance valve

The icon of a connected component is displayed as long as the component is running.

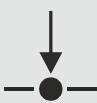

Status display while operation is running

Icons for control status

Icon	Meaning
	Pump down – continuous pumping
	Pump down: lower pressure limit reached VACUU·LAN: pump down to set pressure Vac control: for 2-point control – pump down to set pressure
	VACUU·LAN: pressure increase to switch on pressure Vac control: preset maximum exceeded
	VARIO control: pump down to set point. Auto mode: pump down and boiling point detection within the preset time interval regarding changing process conditions.
	VARIO control: reaches and tracks boiling point. The next program step starts when the programmed pressure has been reached or the preset time has elapsed.
	2-point control: pressure in hysteresis, pump switched on
	2-point control: pressure in hysteresis, pump switched off
	Turbo mode switched on (for VARIO® pump in combination with turbomolecular pump)

Additional information

Information icons



Icon	Meaning
	Clock - Program completed* - Mode VACUU·LAN: delay time elapses
	Lock – operation locked
HI	HI mode for Pump down = optimum speed for the respective pressure.
..%	Percentage value for Pump down motor speed.
100 	Set value for Vac control.

* The clock icon keeps flashing until the **Start/Stop** button has been pressed to acknowledge the end of program.

Fault indication (warning symbol)

	Icon	Meaning
Error display		Flashing: warning!





When device connected to SUB-D (Option)

	Icon	Meaning
Active connection to RS232 port		Controller in remote mode; controller only controllable via connected PC or Notebook, local operation disabled.
		VACUU·CONTROL®-adapter connected; Remote and local operation possible. → Remote operation via end device (e. g., PC, Smartphone).

5.2.3 Signal sounds (warning beep)

Setting *Sound On* in menu **Configuration/Display** is required to hear the audio signals.

Meaning audio signal

	Audio signal	Meaning
Audio signal (beep)	1x  	Short beep for each keystroke.
	2x  	Audio warning for error indication. In short intervals a number of warning beeps are to be heard. This Audio warning is active until error clearance or reset.

 Error messages are indicated by differing numbers of beeps (audio warning).
 For the list of possible warning beeps → see chapter **8.1 Error display**.

5.2.4 Menu display in general

The controller includes several menus and submenus, e. g., **Configuration**, **Function**, **Display**....

Submenu

→ Example
Submenu
Configuration

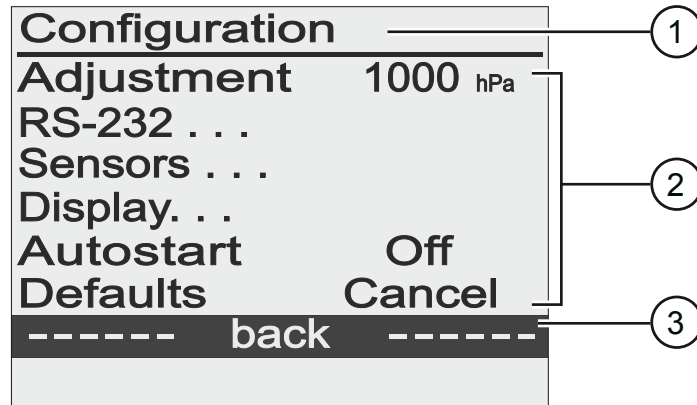

Meaning

1 Titel bar	▶ Menu name
2 Menu interface	▶ Selectable functions or submenus (on the right side of the display) ▶ Adaptable value or ▶ selectable content
3 Back (return)	▶ Call-up previous menu or ▶ previous display



For detailed descriptions about individual menus,
→ see chapter **7.1 Operation menus**.

5.3 Handling CVC 3000

Handling and Operation

The handling of the controller is menu-driven. Menus are accessed via push buttons on the control panel or via key combinations. Use the selection knob to select function or menu.

Operating steps and actions are displayed by an illustration, which is complemented by action symbols.

→ see chapter 1.2.2 *Symbols and icons*.

Navigation

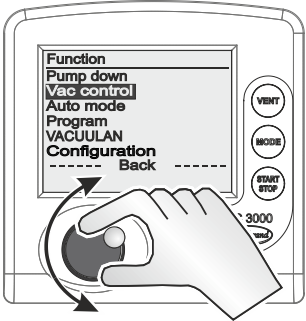

Turn selection knob to select a menu by shifting the bar marking.

→ **bar marking** up/down.

Submenus



Submenus are highlighted with points.

Selection

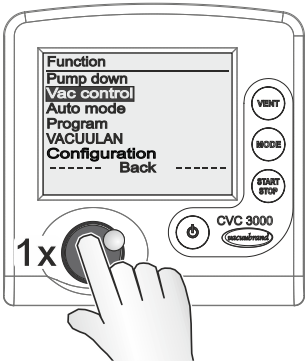

Press selection knob to confirm selection.

Input (data entry)

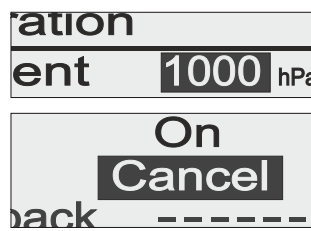

Changeable values are positioned on the right side in the display.

Text on the right side accords to content selection like in a drop down list.

Exception: menu **Program**, in this menu data and value are editable.

Example: enable entry and edit

1. Select the required line and press selection knob.
 - Marking jumps to the input field.
 - Input/Content selection enabled.
2. Turn the selection knob.
 - Value/Content changes.
3. Adapt the numeric value within the specified min/max range or select the required function out of the available content.
4. Confirm input/selection by pressing the selection knob.
 - Value is stored or
 - selected function starts.

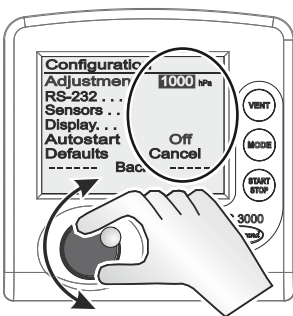

Back (return)

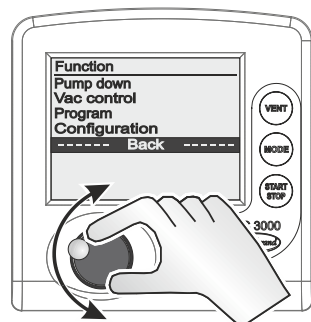

Place the bar marking on line **back** and press the selection knob to return to previous menu, display or to pressure display.



In submenu **Sensors** the display returns to previous menu only after the selection of a sensor.

6 Operation

6.1 Switch-on/-off controller

Switch-on

Switch-on CVC 3000

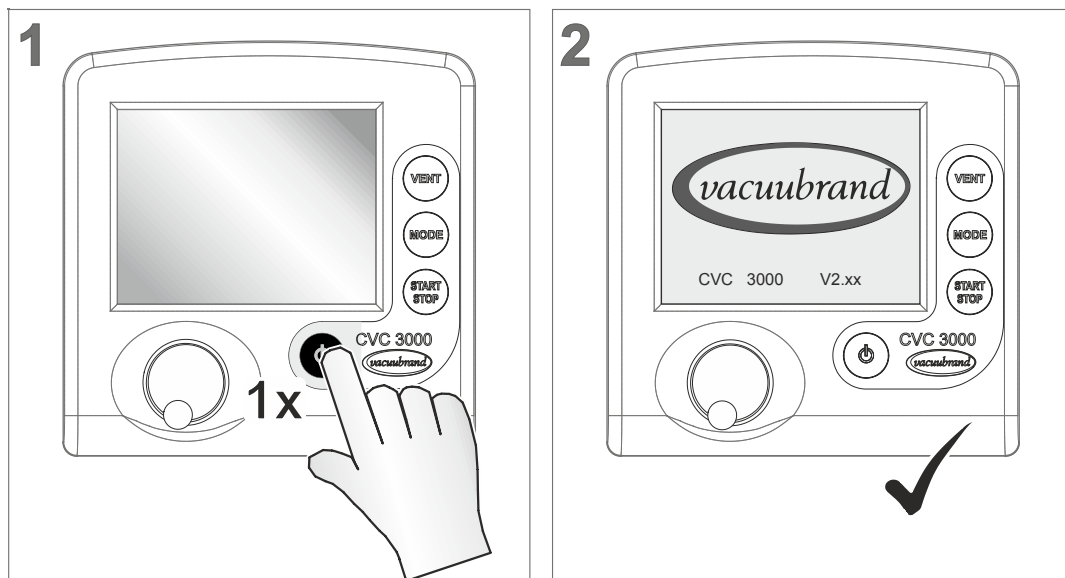

- Initial screen: company logo and firmware version, for approximately 2 seconds.
- Pressure graphic is displayed.

Switch-off

Switch-off CVC 3000

⇒ Press key *On/Off*

- Controller switched off (display off).

6.2 Select language and pressure unit

Select language and pressure unit

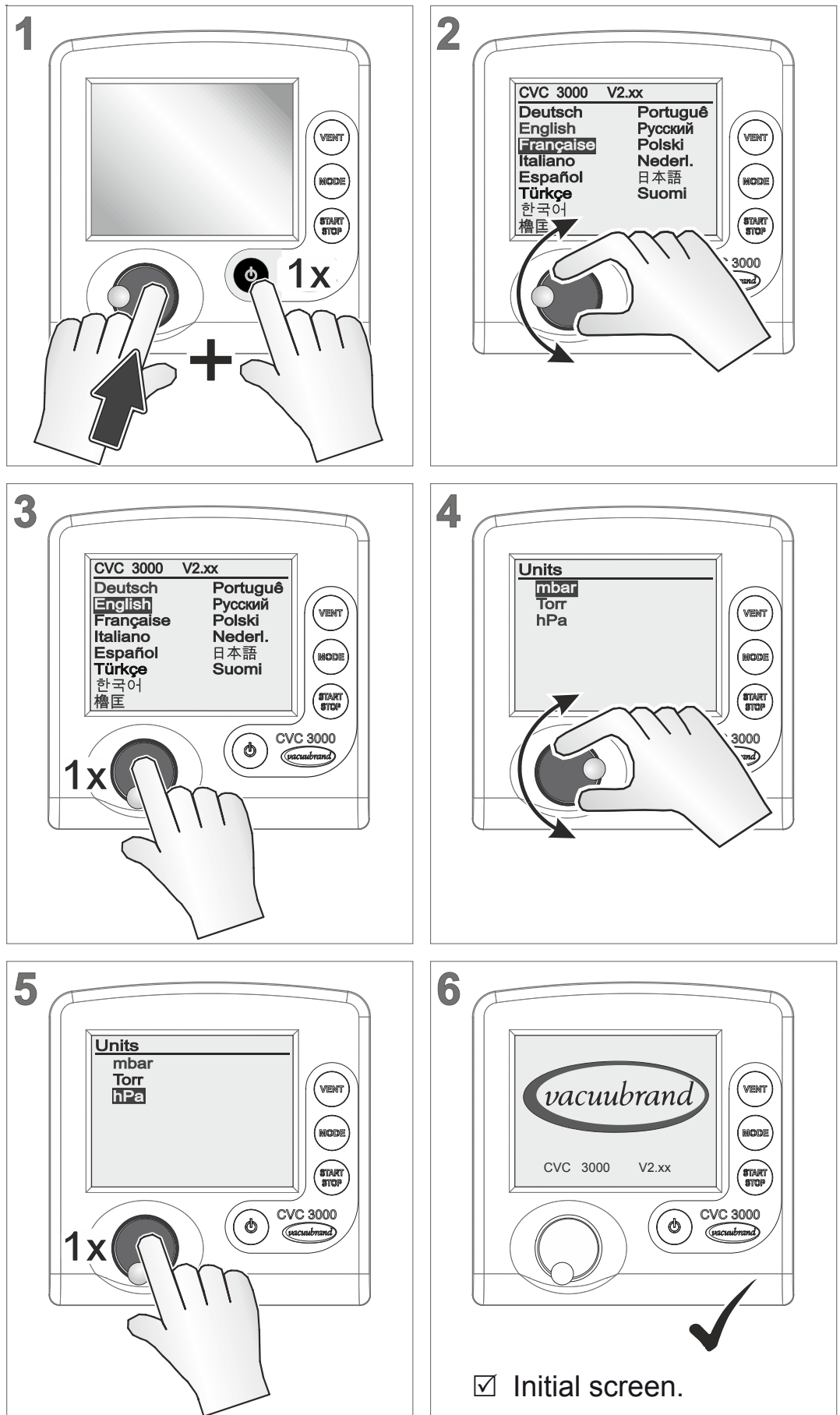

6.3 Mode – Operation mode

MODE

The controller is supplied with several operating modes. Only when the controlling process is stopped it is possible to select an operation mode.

6.3.1 Select operation mode

→ Example
Call-up mode menu

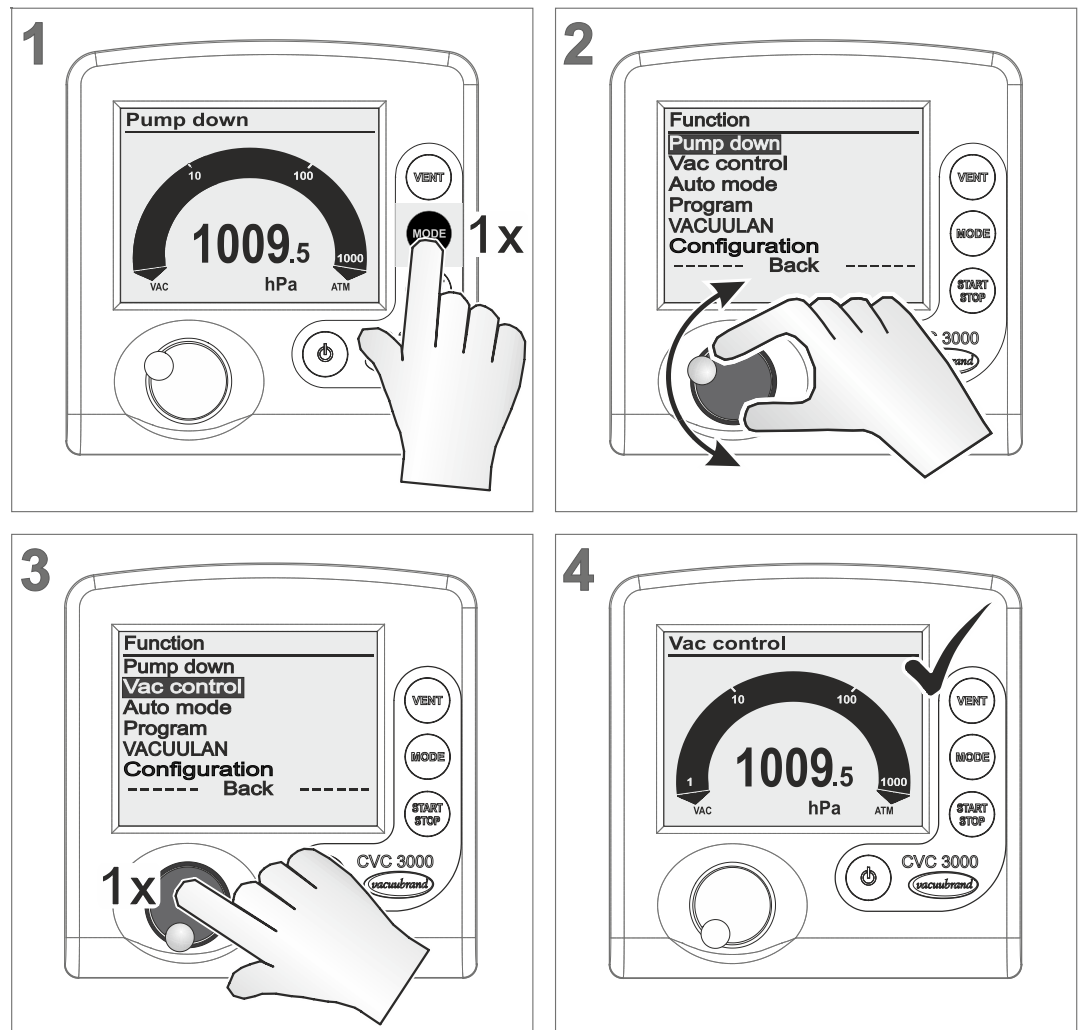

- Title bar shows the selected operation mode (**Mode**).



Select any other operation mode in the same way as described above for **Vac control**.

After 20 seconds without action, the display will return automatically to pressure display.

6.3.2 Mode menu

Mode menu display

→ Example
Menu description

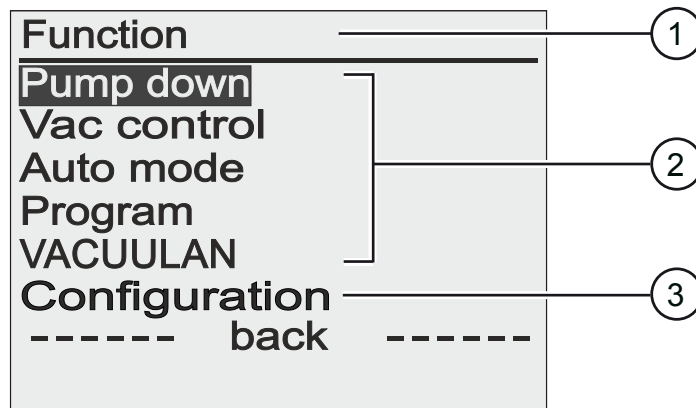

Meaning and
operation modes

1 Title bar menu name
2 Selectable operation modes
<p>Pump down</p> <ul style="list-style-type: none"> ▶ Continuous pump down or ▶ pump down with pressure and time presetting. ▶ VARIO®: Pump down with adjustable motor speed (pumping speed) and continuous speed control.
<p>Vac control</p> <ul style="list-style-type: none"> ▶ Control to a preset vacuum value.
<p>Auto mode</p> <ul style="list-style-type: none"> ▶ Controlling a VARIO® pump in <i>Auto mode</i>: Detect and track boiling point automatically, exact vacuum adaption even with flexible process conditions. <p><i>Listed only with VARIO® pump.</i></p>
<p>Program</p> <ul style="list-style-type: none"> ▶ Load, edit and/or store program. ▶ Max. 10 programs with pressure and time presetting.
<p>VACUULAN</p> <ul style="list-style-type: none"> ▶ Control of the vacuum pump according to demand, optimized for vacuum networks. <p><i>Listed only with VARIO® pump or VMS module, e. g., for pump control.</i></p>
3 Menu Configuration

⇒ Select the mode suitable for vacuum apparatus and planned process.

6.4 Start controlling

START
STOP

Start vacuum controlling after selecting the required operation mode. The controller works in delivery status with the default settings of the factory setting.

Start controlling

→ Example
Start CVC 3000

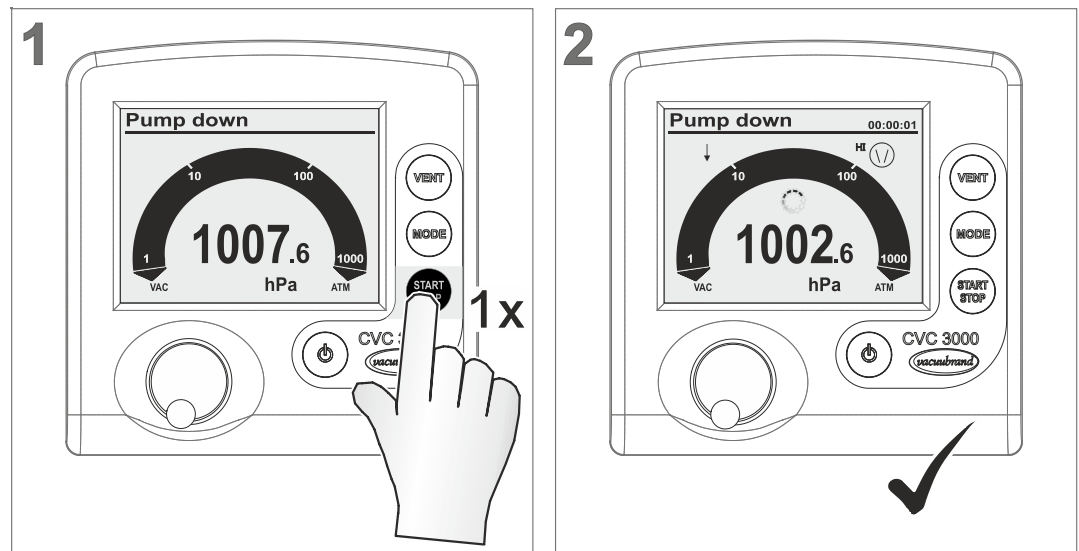

- Controller starts.
- Icons are displayed.

6.5 Control during operation

6.5.1 Venting (VENT)

	DANGER
	<p>Danger of explosion when venting with air by forming of explosive mixtures.</p> <p>Depending on the process venting can cause formation explosive mixtures.</p> <ul style="list-style-type: none"> ⇒ Never vent processes with air which can form explosive mixtures. ⇒ If necessary vent with inert gas (max. 1.2 bar absolute).

IMPORTANT!

Certain processes may cause overpressure.

VENT

Venting

The **VENT** button is used to vent the system. A short click on this button will momentarily vent the system as the process continues. Holding the **VENT** key for longer than 2 seconds will cause the system to be vented to atmospheric pressure and the pump will stop running; max. 1060 mbar (795 Torr). Continuous venting stops when pressing **VENT** key again.

Momentarily venting

→ Example
Momentarily venting

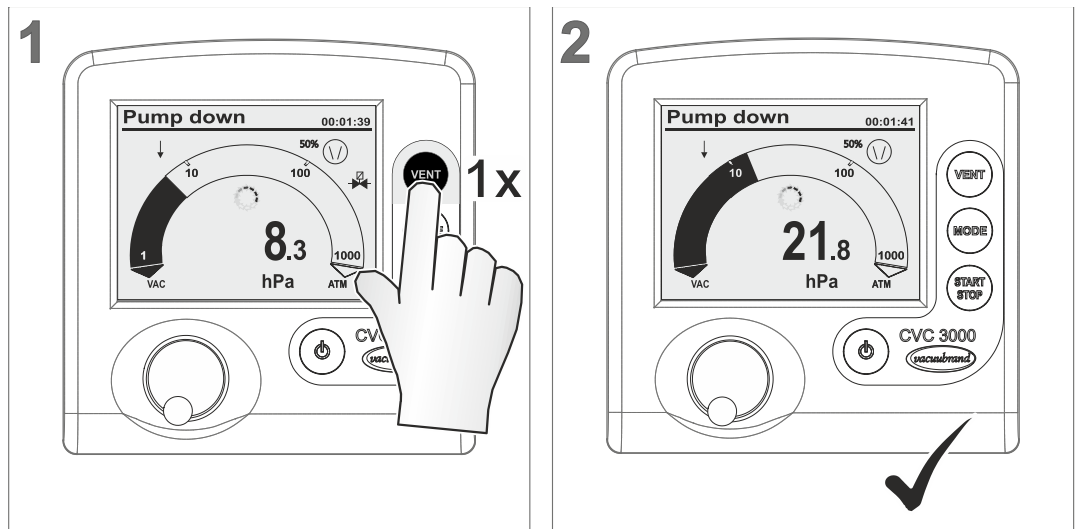

- Venting impulse, venting valve respectively air admittance valve opens momentarily → short-term pressure increase.

Continuous venting

→ Example
Continuous venting

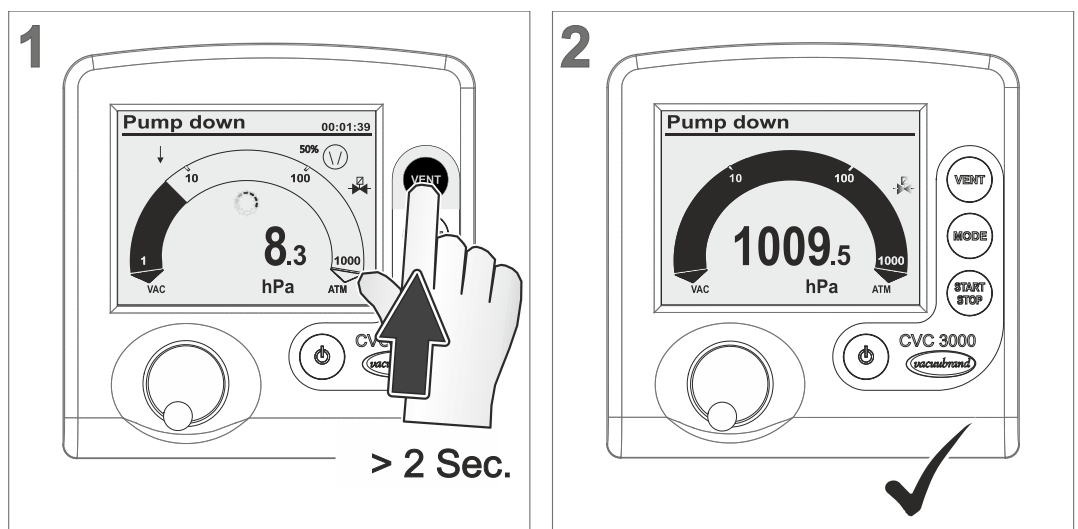

- Icon for venting valve is flashing,
- Venting valve opens → continuous pressure increase until atmospheric pressure → venting valve closes.
- Controller stops.

6.5.2 Change operation mode

MODE

During running operation the operation mode can be switched between *Pump down*, *Vac control* and *Auto mode*¹ by pressing *Mode* key.

Switch mode during running operation

→ Examples
Switch mode

Pump down
↓
Vac control

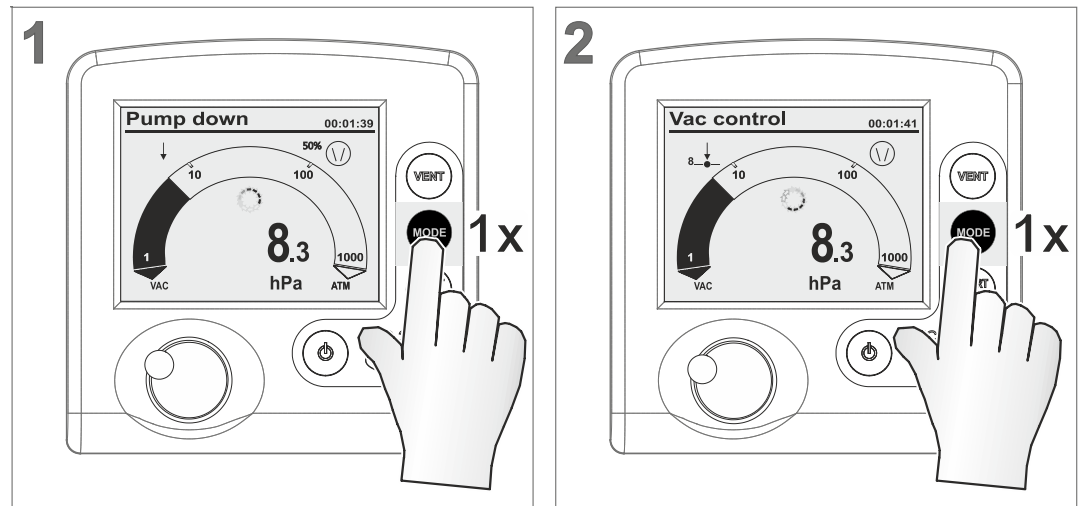

☑ Operation mode switched to *Vac control*.

↓
Auto mode
↓
Vac control
with **VARIO**[®]

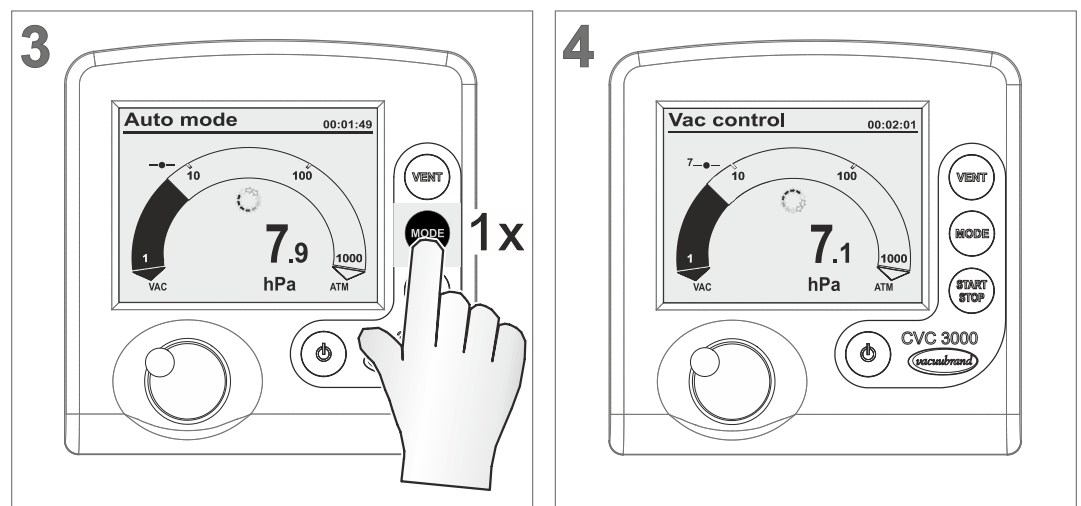

☑ Operation mode switched from *Vac control* to *Auto mode*¹ and back.

☑ Set vacuum adopted from last status in *Auto mode*¹.

¹ -> Only when connected to **VARIO**[®] pump.

Switch back from **Vac control** to **Pump down**.

Switch back to primary mode

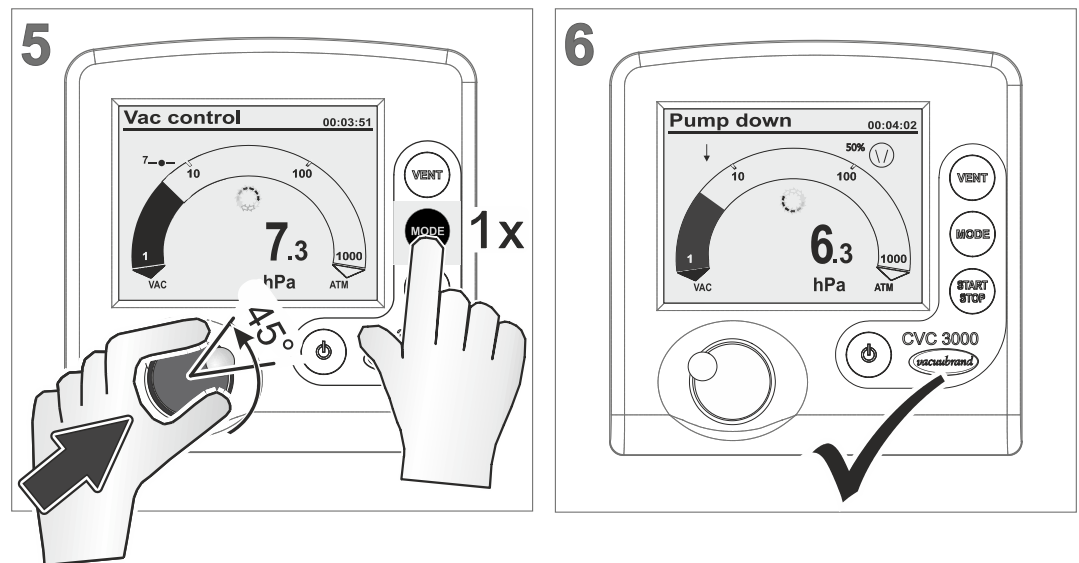

Title bar displays **Pump down**.

Typical applications

Pump down → **Vac control**:

Semiautomatic distillation. Recommended for applications for which the process vacuum is still to be determined. Firstly the vacuum pump is pumping down rapidly in mode **Pump down**. As soon as the required process vacuum has been reached, e. g., boiling vacuum, this vacuum can be maintained by switching to **Vac control**. The actual pressure is adopted as the required set vacuum.

Auto mode ⇔ **Vac control**:

With a connected **VARIO**[®] pump a controller working in **Auto mode** will detect and track the boiling point automatically. The vacuum will be adapted continuously to the process.

If a particular process vacuum is required, the mode can be switched back again to **Vac control**.



Switching the mode during operation via **Mode key works only temporarily. After stopping the controller switches back to its primary mode.**

6.5.3 Display graphic (curve)

Pressure history

In addition to the bar graphic of the pressure display the display can be switched to a diagram named **Graphic** which shows a pressure vs. time curve.

That **Graphic** curve will only be displayed while operation is running. With each start the recording restarts.

Call up graphic

→ Example
Call up pressure
history display

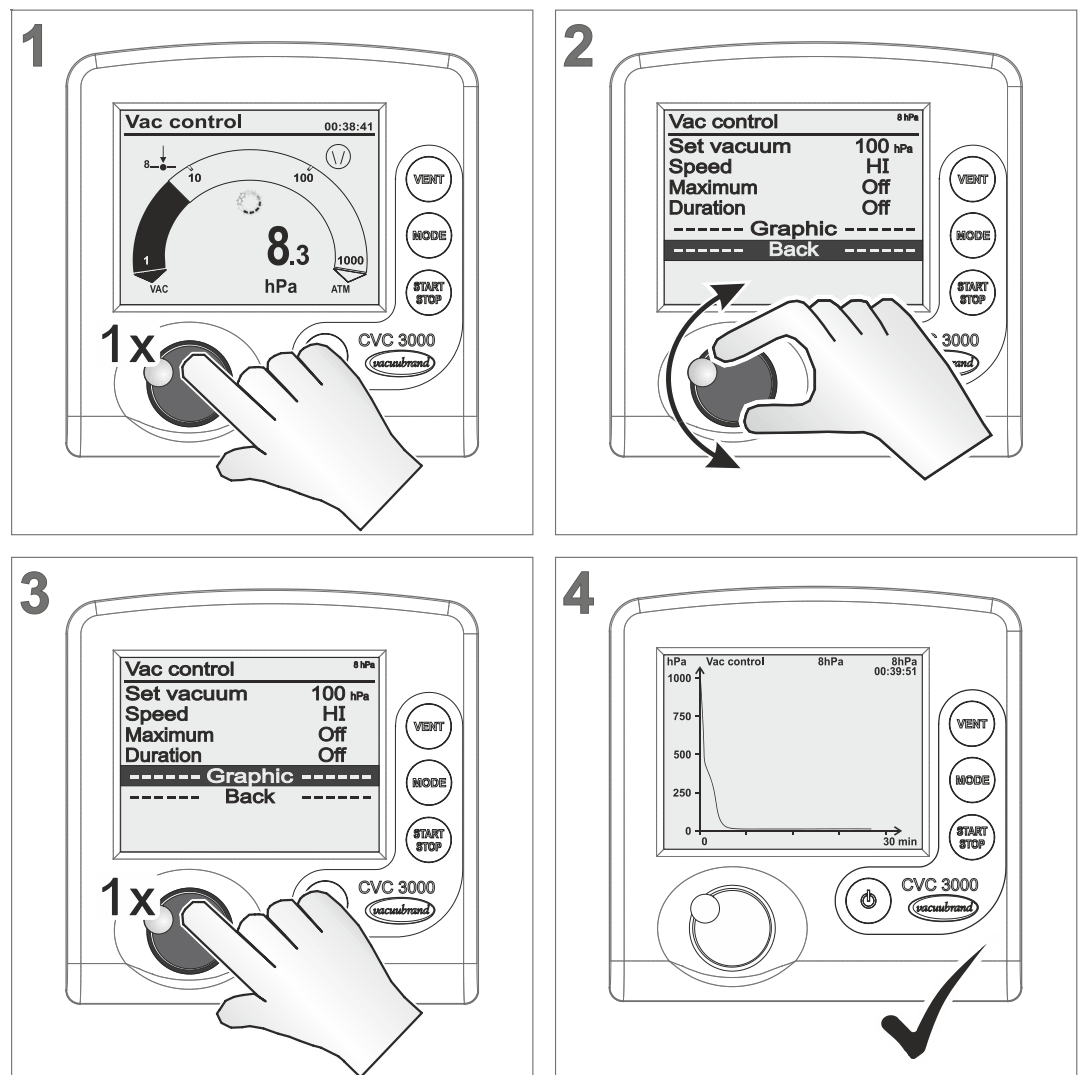

- Graphic** menu is displayed with the pressure curve of the actual process.



To call up **Graphic** with pressure history for other operation modes, do like described above.

Graphic menu

Description pressure history display

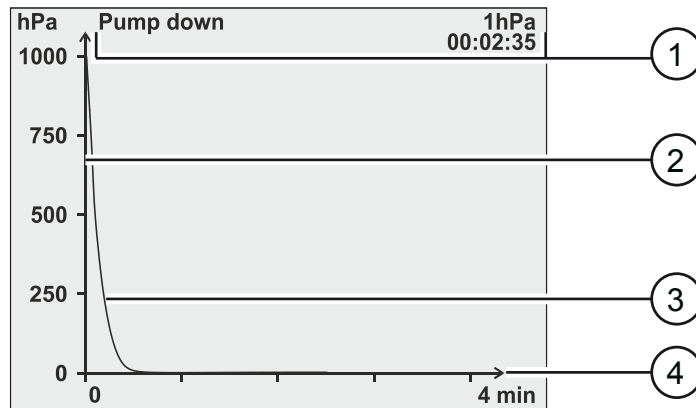

Meaning

- 1 Header**
 - ▶ Active operation mode.
 - ▶ Vacuum set point; for *Vac control* or *Auto mode*.
 - ▶ Actual vacuum value (actual pressure).
 - ▶ Elapsed process time.
- 2 Axis – pressure**
 - ▶ Unit according to pre-settings (mbar, Torr, hPa).
- 3 Pressure graph**
 - ▶ Pressure/time progress.
- 4 Axis – time**
 - ▶ Continuous, automatically scaling time (minute, hour).

6.5.4 Quit display graphic

Return to pressure display

→ Example
Switch back to
basic display

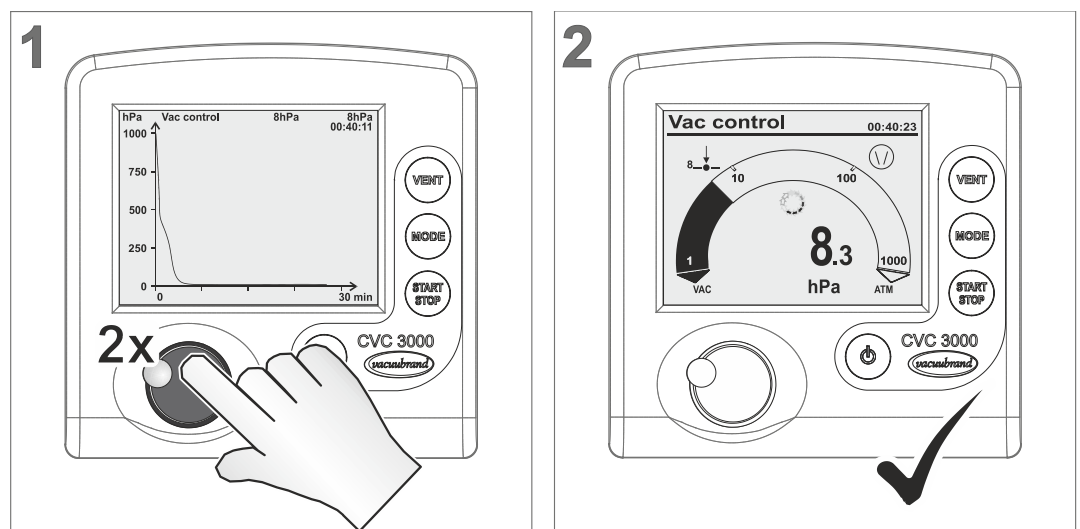

- View basic display.

6.6 Quick adaption during operation

6.6.1 Set vacuum

In mode **Vac control** the set vacuum can be adapted directly during running operation.

Adapt set vacuum → fine tuning

1 detent = 1 pressure value (mbar, Torr, hPa)

→ Example
Adapt set vacuum
fine tuning

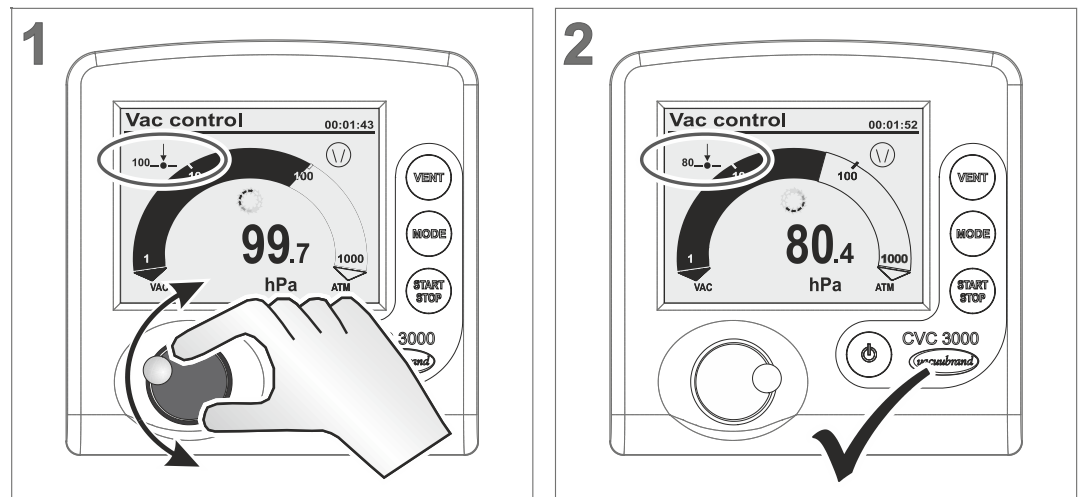

Controller controls to new set vacuum.

Adapt set vacuum → quick tuning

→ Example
Adapt set vacuum
quick tuning

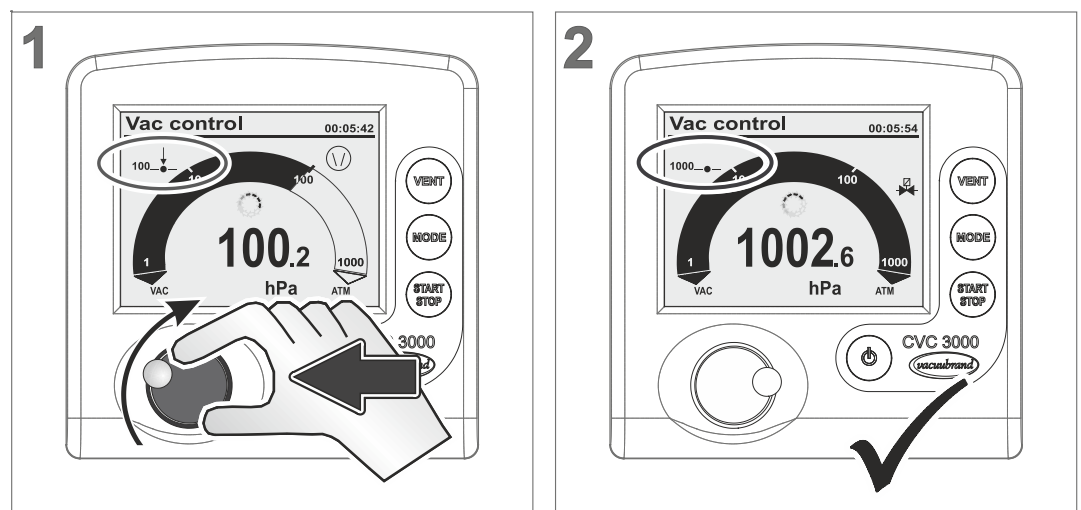

⇒ Press selection knob and turn it clockwise: increase set vacuum (venting).

⇒ Press selection knob and turn it anticlockwise: decrease set vacuum (vacuum pump on).

Controller controls to the new set vacuum which is displayed while releasing the selection knob.

6.6.2 Motor speed (only VARIO®)

In mode **Pump down** the motor speed of a **VARIO®** pump can be adjusted directly during running operation.

Pump down – adjust motor speed

→ Example
How to change
motor speed

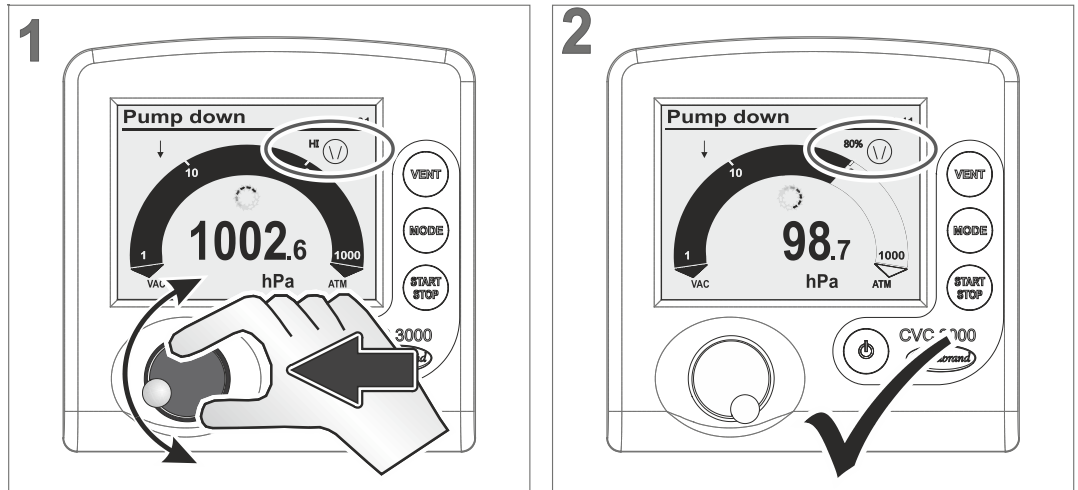

- ☑ Pump icon with percentage value.
- ☑ **VARIO®** pump runs with adjusted motor speed.

6.7 Stop control

Stop control

→ Example
Stop CVC 3000

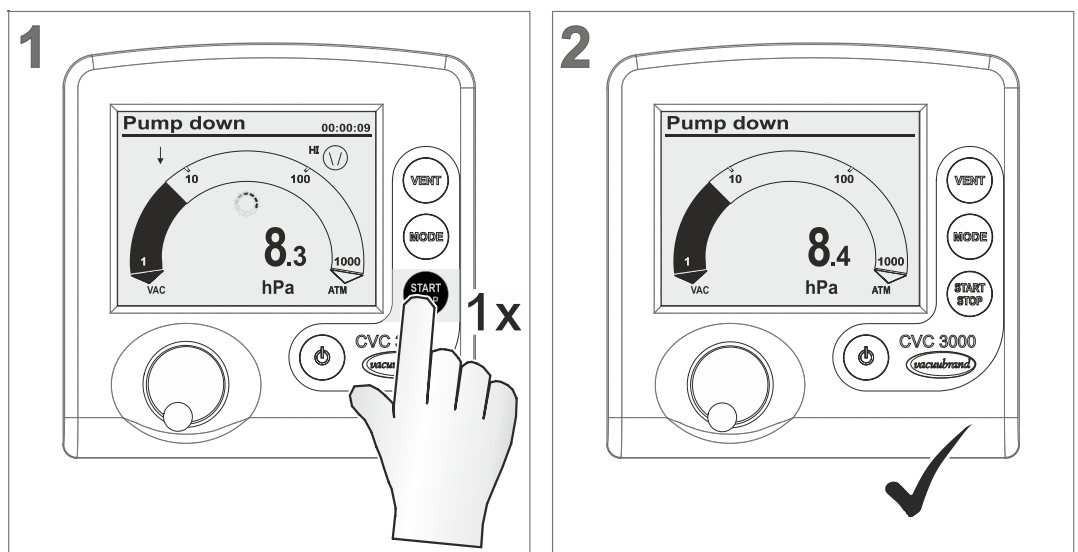

- ☑ Controller and vacuum control stops.
- ☑ Display icons switched off.

7 Advanced menus and operation

7.1 Operation menus

Optimizing operation mode

A selected operation mode can be adapted and optimized for the process through the corresponding operation menu. The settings in an operation menu include mainly: motor speed, set vacuum or time presets. Settings in operation menus are retained also after switching on/off.

Menu **Program** is for storing up to 10 individual programs, e. g., to store control settings for frequently repeated processes.

Call up submenu of an individual operation mode

→ Example
Call up operation menu

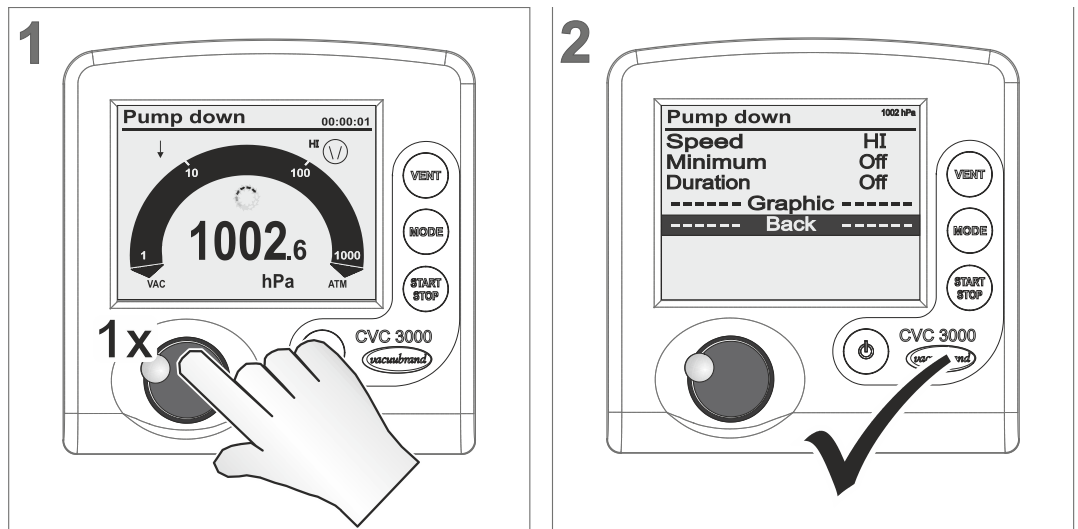

- Corresponding menu of the preset operation mode is displayed.

To call up an operation menu, press the selection knob. Adaptions are possible during a running process as well as when control is stopped.



Use operation menu to optimize vacuum control for application requirements.

7.1.1 Pump down

Meaning Continuous pump down with pressure and time presets.

Menu – Pump down

→ Example
Operation menu
Pump down

Pump down		1013 hPa
Speed	HI	
Minimum	Off	
Duration	Off	
----- Graphic -----		
----- Back -----		

Parameter
Pump down

Parameter	Meaning
Speed (%)	VARIO [®] : Speed settings for pump down. Adjustment range: 1–100; HI*
Minimum** (mbar, Torr, hPa)	Vacuum set point; once reached, the controller switches off the vacuum pump or closes the in-line valve. Adjustment range: Off; 1–1060
Duration** (min)	Presetting process runtime from Start on. Adjustment range: Off; 1–1440
Delay (min)	Delay time for an optional coolant valve. Adjustment range: Off; 1–300

* HI mode: optimum speed for the respective pressure.

** If **Minimum** and **Duration** are set to **OFF**, pump down has to be stopped by pressing **START/STOP** key.

Application example – cabinet dryer

Application example
for Pump down

Set **Minimum** to a vacuum value below boiling pressure and the controller will switch the vacuum pump off, once the liquid has completely evaporated.

7.1.2 Vac control

Meaning Control to a set vacuum value.

Menu – Vac control

→ Example
Operation menu
Vac control

Vac control		1002 hPa
Set vacuum	100	hPa
Speed	HI	
Maximum	Off	
Duration	Off	
----- Graphic -----		
----- Back -----		

Parameter
Vac control

Parameter	Meaning
Set vacuum (mbar)	Setting for lower vacuum level for 2-point control or precisely for VARIO ® pump. Adjustment range: Turbo*; 1–1060
Speed (%)	VARIO ®: Speed settings for pump down. Adjustment range: 1–100; HI**
Hysteresis*** (mbar, Torr, hPa)	Only for VMS or in-line valve with vacuum pump: control range for 2-point control. Adjustment range: Auto; 1–300
Maximum (mbar, Torr, hPa)	Setting for upper vacuum level. Once reached, control switches off. Adjustment range: Off; 1–1060
Duration (min)	Presetting process runtime from Start on. Adjustment range: Off; 1–1440
Delay (min)	Delay time for an optional coolant valve. Adjustment range: Off; 1–300

* Turbo mode: auto-adapting vacuum control for best ultimate vacuum. Best backing pressure for operation with a turbomolecular pump.

** HI mode: optimum speed for the respective pressure.

*** VARIO pumps work without hysteresis.

Application example – filtration

Application example
for Vac control

Set the set vacuum higher than the boiling pressure of the liquid and set **Maximum** value even a little bit higher. If the filter runs dry or if the filter is fractured, the pressure will increase and the control will be stopped automatically.

Hysteresis values Auto

Factory settings
Hysteresis

Set vacuum (mbar)	5	10	50	80	100	200	500	700	900	1000
Hysteresis (mbar)	2	2	5	8	9	17	40	55	71	78

7.1.3 Auto mode (only valid for VARIO® pump)

Meaning Automatic detection and tracking of boiling point, unaffected by varying process conditions.

Menu – Auto mode

→ Example
Operation menu
Auto mode

Auto mode		999 hPa
Sensitivity	Normal	
Speed	HI	
Minimum	Off	
Duration	Off	
----- Graphic -----		
----- Back -----		

Parameter
Auto mode

Parameter	Meaning
Sensitivity	Setting affects processing speed: Low Fast; large amounts of uncritical solvents Normal Normal; basic setting for almost all distillations High Slow; small amounts, for solvents with tendency to foam
Speed (%)	VARIO® : Motor speed limitation during tracking. Adjustment range: 1–100; HI*
Minimum (mbar, Torr, hPa)	VARIO® : Vacuum setting; once reached, controller stops the VARIO® pump. Adjustment range: Off; Auto**; 2–1060
Duration (min)	Presetting process runtime from Start on. Adjustment range: Off; 1–1440
Delay (min)	Delay time for an optional coolant valve. Adjustment range: Off; 1–300

* HI mode: optimum speed for the respective pressure, recommended setting.

** Complete solvent evaporation will be detected and the process will then be stopped.

Application example – rotary evaporator

Application example for Auto mode

Use *Minimum* to prevent rotary evaporator from receiving re-evaporation from the flask. Set *Minimum* value to the vapor pressure of the solvent at ambient temperature.

7.1.4 Program

Meaning

Up to 10 individual programs including vacuum and time presettings can be loaded, edited, and stored.

Menu – Program

→ Example Operation menu Program

Program 0		1010 hPa
Edit		
Open		0
Store		0
----- Graphic -----		
----- Back -----		

Parameter Program

Parameter	Meaning
Edit	Edit program with presettings for a process cycle or edit an existing program.
Open	Load the selected program.
Store	Store the program under the selected number. (memory capacity for up to 10 programs)
Hysteresis (mbar, Torr, hPa)	Only for VMS or in-line valve with vacuum pump: control range for 2-point control. Adjustment range: Auto; 1–300
Delay	Delay time for an optional coolant valve. Adjustment range: Off; 1–300

Hysteresis values Auto

Factory settings for Hysteresis

Set vacuum (mbar)	5	10	50	80	100	200	500	700	900	1000
Hysteresis (mbar)	2	2	5	8	9	17	40	55	71	78

For further descriptions of program functions → see chapter *7.2 Program functions*.

7.1.5 VACUULAN

Meaning Vacuum control, optimized for **VACUU-LAN®** vacuum networks by VACUUBRAND.

Menu **VACUULAN**

→ Example
VACUULAN display

VACUULAN		1008 hPa
Set vacuum	25	hPa
Switch on	200	hPa
Delay	15	min
----- Graphic -----		
----- Back -----		

Parameter
VACUULAN

Parameter	Meaning
Set vacuum (mbar)	Setting for lower vacuum level, which shall be reached easily when the vacuum network is not used. Adjustment range: 1–1060
Switch on (mbar, Torr, hPa)	Limit for pressure increase. If pressure exceeds this limit, the pump will begin to pump down. Adjustment range: 26–1060
Delay (min)	Delay time for an optional coolant valve after reaching set vacuum. Adjustment range: Off; 1–300

7.2 Program functions

Meaning In menu **Program** presettings for up to 10 different application scenarios can be stored.

Use **Program** for frequently used applications.

7.2.1 Open/Change program

→ Example
Open Program 2

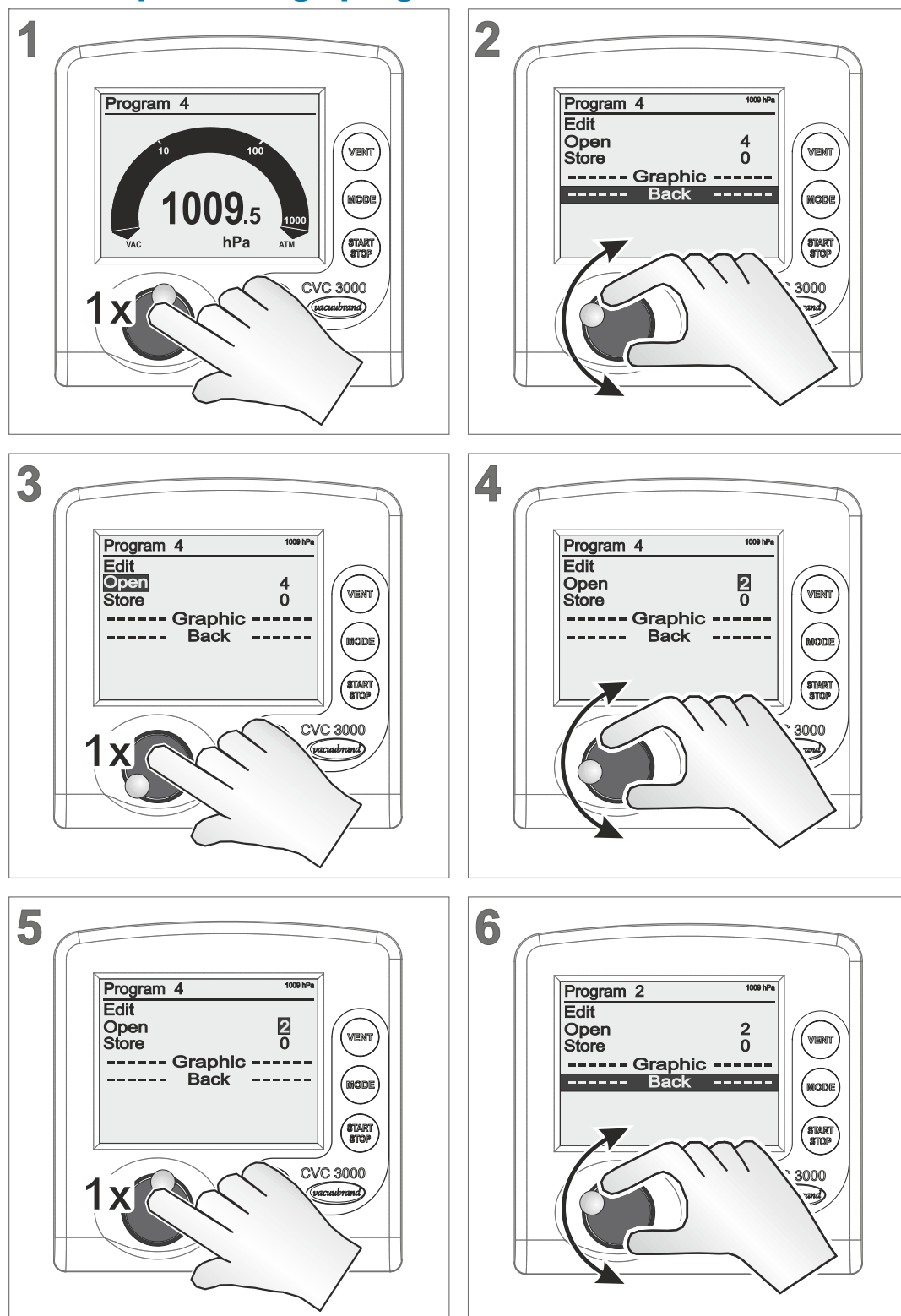

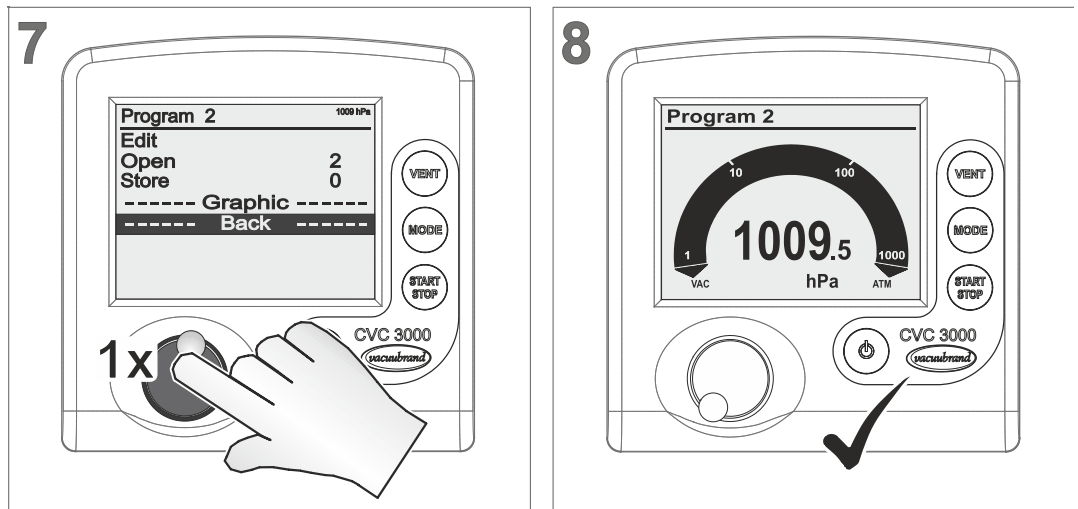

- Controller is running with settings of program 2.
- Program 2 displayed in title bar.

7.2.2 Edit program

Open program editor

→ Example
Call up program
editor

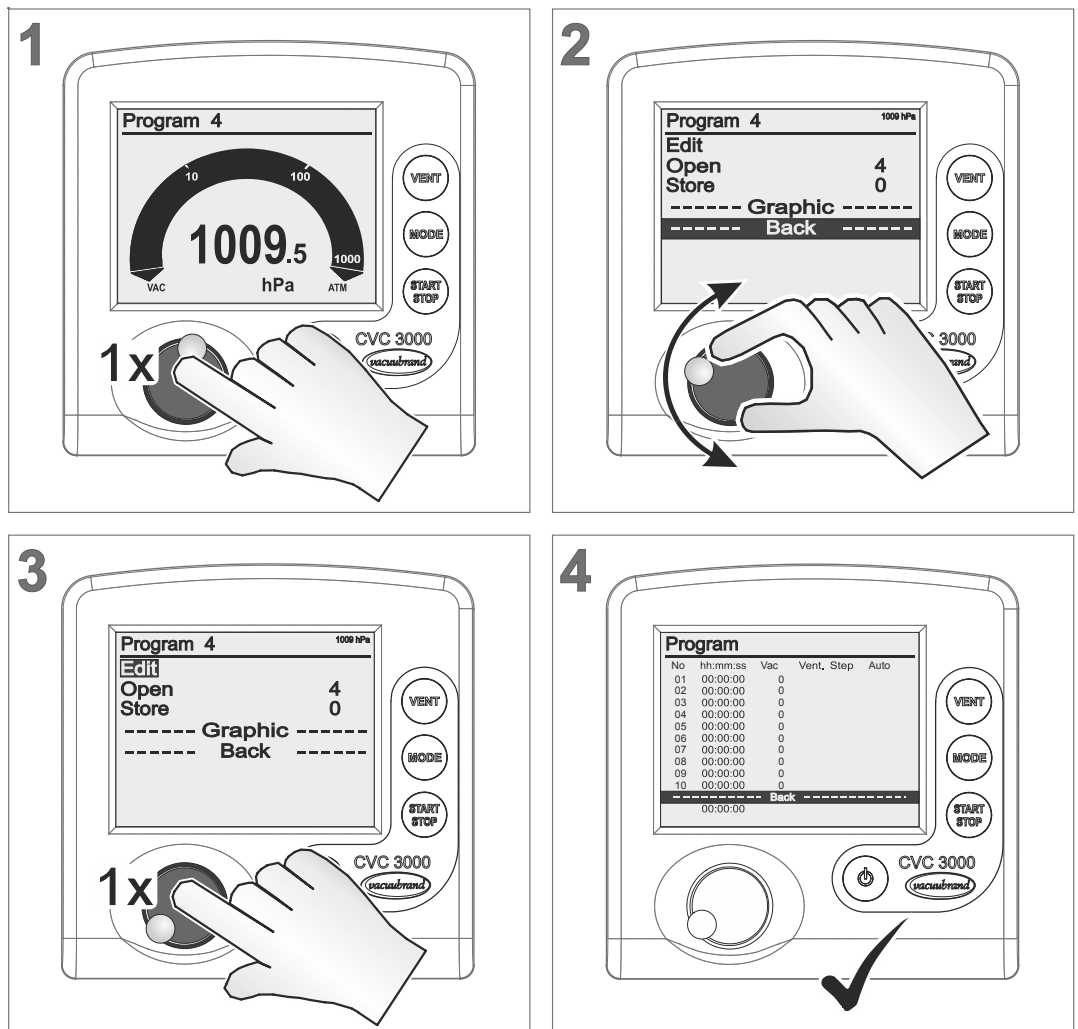

Explanation program editor



→ Example
Menu explanation

Program					
No	hh:mm:ss	Vac	Vent.	Step	Auto
01	00:00:00	ATM	✓	✓	
02	00:05:00	10			
03	00:10:00	10			
04	00:01:00	500	✓		
05	00:09:00	500	✓		
06	00:10:00	5			
07	00:20:00	5			
08	00:01:00	ATM	✓	✓	
09	00:00:00	0			
10	00:00:00	0			
----- back -----					
00:56:00					

- 1 Title bar** menu name
- 2 No**
 - ▶ Number 1–10, sequence of program steps.
- hh:mm:ss**
 - Timer for individual program steps:
 - ▶ Until vacuum value has been reached.
 - ▶ Hold vacuum level.
- Vac**
 - ▶ Preset a vacuum level.
- Vent.**
 - ▶ Controller includes venting valve for control.
- Step**
 - ▶ Reach vacuum level as quickly as possible.
 - ▶ Timer starts after vacuum level has been reached.
- Auto** (displayed only in combination with **VARIO®**).
 - ▶ Detect and track boiling point.
- 3 Program steps**
 - Up to 10 program steps can be edited individually.
- 4 Total runtime**
 - Total amount of time of individual program steps.

Adjustable parameters

Adjustable program
step parameters

hh:mm:ss	00:00:00–99:59:59		
Vac	0–1060; ATM	(Torr: 0–795; ATM)	
	<i>ATM = atmosphere; this starting point is always attainable.</i>		
Vent.	<input type="checkbox"/> Off	<input checked="" type="checkbox"/> On	
Step*	<input type="checkbox"/> Off	<input checked="" type="checkbox"/> On	
Auto*	<input type="checkbox"/> Off		Pump down and boiling point detection within the preset time interval regarding changing process conditions.
	<input type="checkbox"/> Off		Reaches and tracks boiling point. The next program step starts when the programmed pressure has been reached or the preset time has elapsed.

* either selection **Step** or **Auto** possible.

NOTICE

Unlimited program runtime.

A time adjustment of 99:59:59 in program step No 10 is equal to an unlimited program runtime.

⇒ If necessary, stop process by pressing **Start/Stop** key.

Create a program

NOTICE

Input only enabled for 5 seconds.

The time frame for inputs is 5 seconds. If this time expires without any input, the edit frame (= input enabled) returns to bar marking. Only input confirmed by selection knob will be stored.

⇒ First of all write down the complete program. Take these notes in order to carry out programming quickly and uninterrupted.

→ Example
Creating a new
program

Program						1
No	hh:mm:ss	Vac	Vent.	Step	Auto	
01	00:00:00	0				
02	00:00:00	0				
03	00:00:00	0				
04	00:00:00	0				
05	00:00:00	0				
06	00:00:00	0				
07	00:00:00	0				
08	00:00:00	0				
09	00:00:00	0				
10	00:00:00	0				
----- back -----						
00:00:00						

Program						2
No	hh:mm:ss	Vac	Vent.	Step	Auto	
01	00:00:00	0				
02	00:00:00	0				
03	00:00:00	0				
04	00:00:00	0				
05	00:00:00	0				
06	00:00:00	0				
07	00:00:00	0				
08	00:00:00	0				
09	00:00:00	0				
10	00:00:00	0				
----- back -----						
00:00:00						

1. Open program editor → see 7.2.2 *Edit program*.
2. Turn the selection knob and place the bar marking onto the line of program step No 01.

Program						3
No	hh:mm:ss	Vac	Vent.	Step	Auto	
01	00:00:00	0				
02	00:00:00	0				
03	00:00:00	0				
04	00:00:00	0				
05	00:00:00	0				
06	00:00:00	0				
07	00:00:00	0				
08	00:00:00	0				
09	00:00:00	0				
10	00:00:00	0				
----- back -----						
00:00:00						

Program						4
No	hh:mm:ss	Vac	Vent.	Step	Auto	
01	00:01:00	0				
02	00:00:00	0				
03	00:00:00	0				
04	00:00:00	0				
05	00:00:00	0				
06	00:00:00	0				
07	00:00:00	0				
08	00:00:00	0				
09	00:00:00	0				
10	00:00:00	0				
----- back -----						
00:01:00						

3. Press the selection knob to start editing program step No 01.
 - ☑ Edit frame enabled.
4. Turn the selection knob to set the desired time, e. g., 1 minute and then press selection knob to confirm input.
 - ☑ Edit frame switches to next position.

→ Example
Create a new
program

Program						5
No	hh:mm:ss	Vac	Vent.	Step	Auto	
01	00:01:00	ATM	<input type="checkbox"/>			
02	00:00:00	0				
03	00:00:00	0				
04	00:00:00	0				
05	00:00:00	0				
06	00:00:00	0				
07	00:00:00	0				
08	00:00:00	0				
09	00:00:00	0				
10	00:00:00	0				
-----		back	-----			
00:01:00						

Program						
No	hh:mm:ss	Vac	Vent.	Step	Auto	
01	00:01:00	ATM	<input checked="" type="checkbox"/>	<input checked="" type="checkbox"/>		
02	00:00:00	0				
03	00:00:00	0				
04	00:00:00	0				
05	00:00:00	0				
06	00:00:00	0				
07	00:00:00	0				
08	00:00:00	0				
09	00:00:00	0				
10	00:00:00	0				
-----		back	-----			
00:01:00						

- Turn the selection knob to set the required vacuum value, e. g., **ATM** and then press selection knob to confirm input.
 - For **ATM** settings **Vent** and **Step** will be set automatically and setting for **Auto** will be skipped.
 - Bar marking onto program step 02.

Program						6
No	hh:mm:ss	Vac	Vent.	Step	Auto	
01	00:01:00	ATM	<input checked="" type="checkbox"/>	<input checked="" type="checkbox"/>		
02	00:00:00	0				
03	00:00:00	0				
04	00:00:00	0				
05	00:00:00	0				
06	00:00:00	0				
07	00:00:00	0				
08	00:00:00	0				
09	00:00:00	0				
10	00:00:00	0				
-----		back	-----			
00:01:00						

Program						7
No	hh:mm:ss	Vac	Vent.	Step	Auto	
01	00:01:00	ATM	<input checked="" type="checkbox"/>	<input checked="" type="checkbox"/>		
02	00:05:00	0				
03	00:00:00	0				
04	00:00:00	0				
05	00:00:00	0				
06	00:00:00	0				
07	00:00:00	0				
08	00:00:00	0				
09	00:00:00	0				
10	00:00:00	0				
-----		back	-----			
00:06:00						

- Press the selection knob to start editing program step No 02.
 - Edit frame enabled.
- Turn the selection knob, to set the desired time, e. g., 5 minutes and then press selection knob to confirm input.
 - Edit frame switches to next position.

Program						8
No	hh:mm:ss	Vac	Vent.	Step	Auto	
01	00:01:00	ATM	✓	✓		
02	00:05:00	10	<input type="checkbox"/>			
03	00:00:00	0				
04	00:00:00	0				
05	00:00:00	0				
06	00:00:00	0				
07	00:00:00	0				
08	00:00:00	0				
09	00:00:00	0				
10	00:00:00	0				
-----		back	-----			
00:06:00						

Program						9
No	hh:mm:ss	Vac	Vent.	Step	Auto	
01	00:01:00	ATM	✓	✓		
02	00:05:00	10				
03	00:00:00	0				
04	00:00:00	0				
05	00:00:00	0				
06	00:00:00	0				
07	00:00:00	0				
08	00:00:00	0				
09	00:00:00	0				
10	00:00:00	0				
-----		back	-----			
00:06:00						

8. Turn the selection knob to set the required vacuum value, e. g., 10 mbar. Afterwards press selection knob repeatedly until the bar marking is placed onto program step 03.
9. For further input do like described above for program step 01 and 02.

NOTICE

If not stored, edited programs be will be deleted from memory store after switching the controller ON/OFF.
 ⇒ Save the edited program under a free program number.

Example: display of a program, which is not yet stored.

Program -

Program - : 1

7.2.3 Store program

IMPORTANT!

⇒ Store the edited program under a free program number.

Store program under a program number

→ Example
Store program

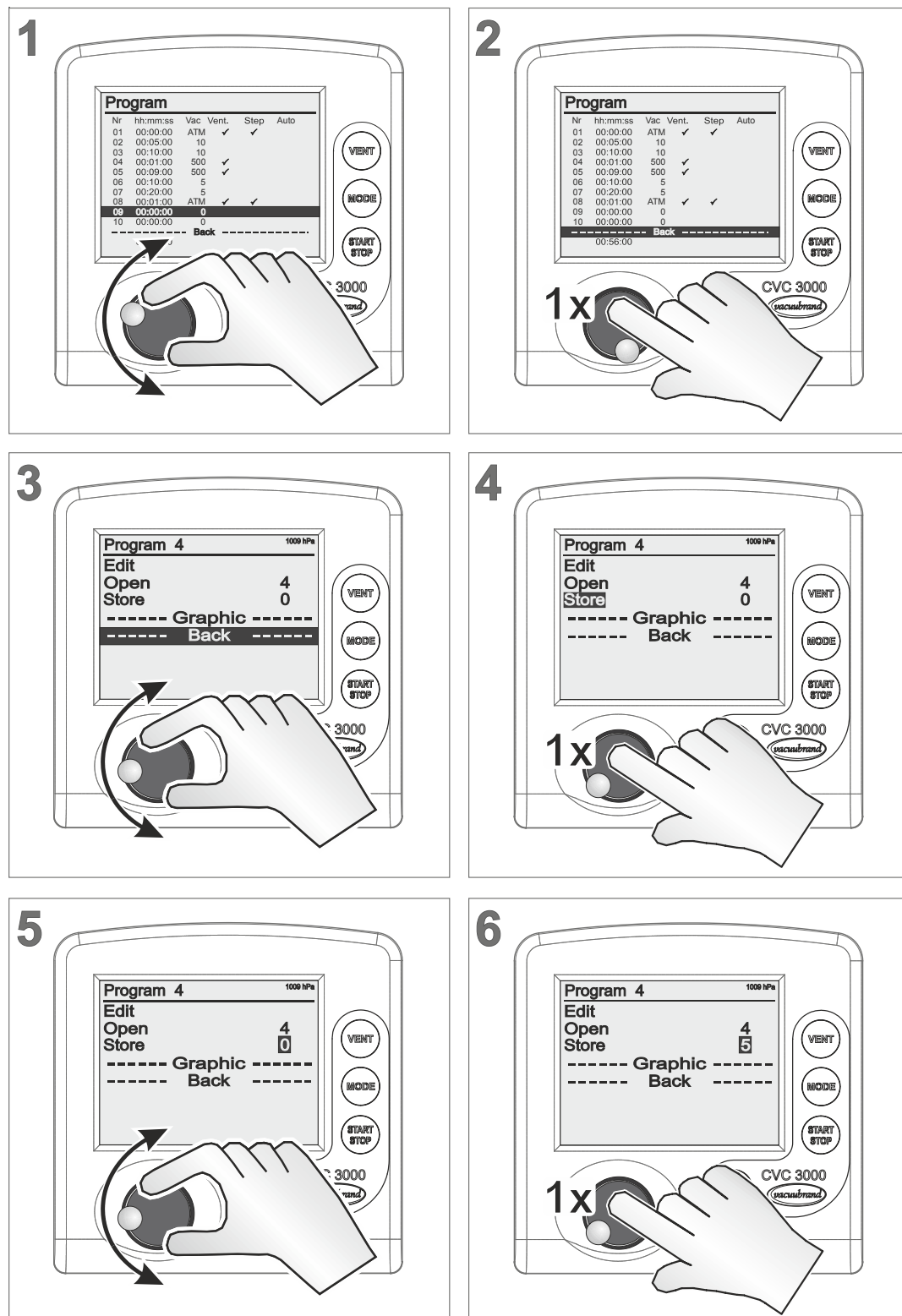

→ Example Store program

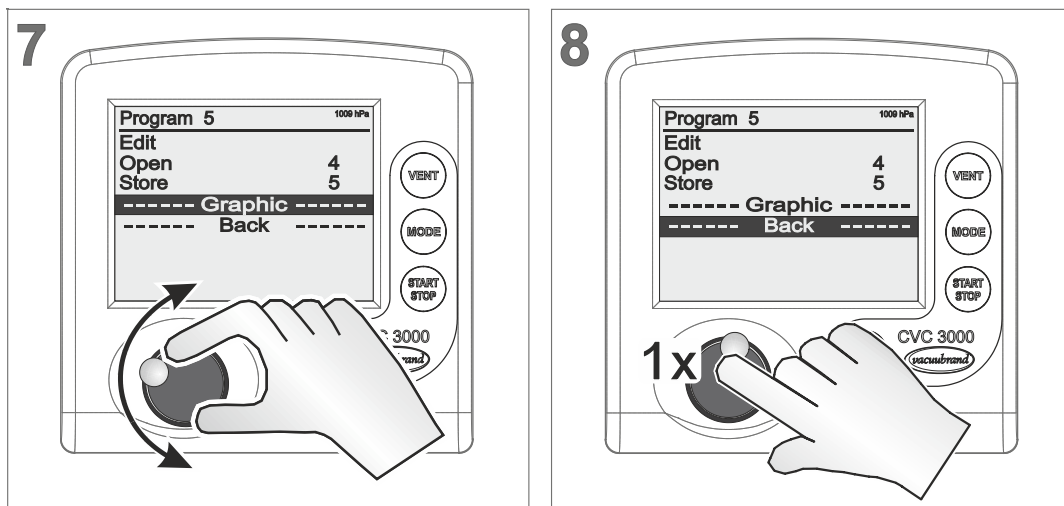

- ☑ Program stored under program number 5.
- ☑ Display switches to pressure display.

7.2.4 Display during operation

Program 1:2

As long as a program is running, the title bar displays additionally the current program step, e. g., Program 1 in program step 02.

Program display during operation

→ Example Running program with program steps

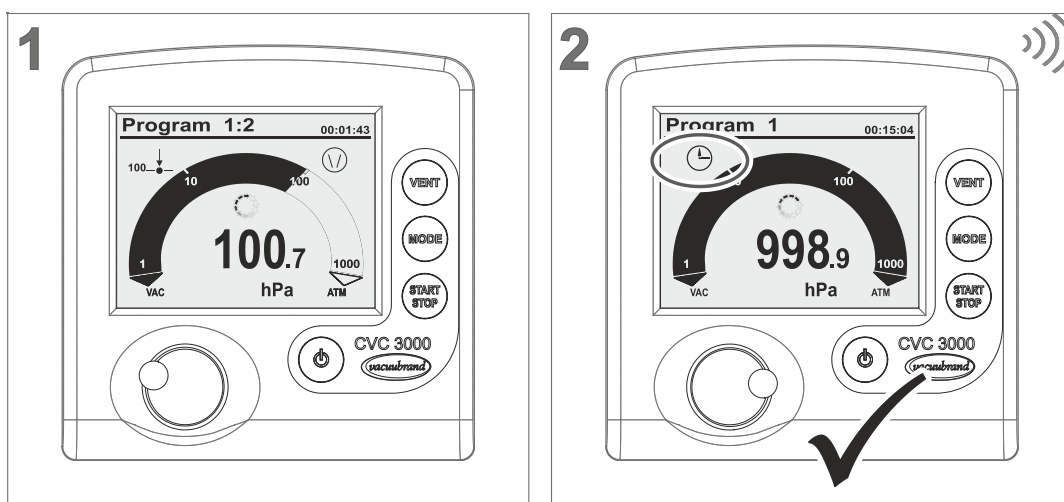

- ☑ Program step blanked.
- ☑ Flashing clock icon = program time elapsed.
- ☑ Warning sound indicates *program time has elapsed*.

⇒ Press **Start/Stop** key, to acknowledge completed program.

7.2.5 Program memory

Meaning The last used process settings remain in the program memory until switching off the controller = temporary buffer.

The program memory provides advantages in practice:

- Operational data in the program memory to repeat the last process in mode **Program**.
- Reproducible test processes: Save the operational data as program directly after process end.
- Facilitate programming, because operational data are already written in the program editor.
- Simple modification of programs for similar processes.

Example: Test procedure for a new substance

→ Example	20 l parallel evaporator and vacuum apparatus:
Test assembly	Vacuum controller CVC 3000, in-line suction valve, chemistry diaphragm pump MD 4C NT.
Test procedure	In mode Pump down the parallel evaporator was quickly evacuated to a vacuum suitable for the substance. At approximately 14 mbar the mode was switched to Vac control . The process vacuum for the application was corrected to 10 mbar by quick adaption during operation. Duration of the evaporation was approximately 4.5 hours, afterwards the system was vented to atmosphere pressure.

IMPORTANT!

- ⇒ Save important process data.
- ⇒ Leave the controller switched on after process end and
- ⇒ store successful test values as a controller program.

How to use program memory¹

Test values in temporary buffer

1. Press **Mode** key.
2. Turn selection knob to select **Program**.

Title bar: **Program -**.

3. Open the program editor.

Program					
No	hh:mm:ss	Vac	Vent.	Step	Auto
01	00:00:00	1002	✓	✓	
02	00:05:28	14			
03	00:00:07	10			
04	04:29:11	10			
05	00:00:00	75	✓		
06	00:00:32	75			
07	00:00:00	75			
08	00:00:00	75			
09	00:00:00	75			
10	00:00:00	75			
----- zurück -----					
04:35:08					

Listet values of the latest run test set-up appear.

IMPORTANT!

- ⇒ Set **ATM** as first and last program step. The actual atmospheric pressure may vary. Therefore the setting **ATM** is best suited as initial and final status.
- ⇒ Delete zero times because these program steps will be skipped.

4. Edit data like here in the example:

Modified test values

Program					
No	hh:mm:ss	Vac	Vent.	Step	Auto
01	00:00:00	ATM	✓	✓	
02	00:05:30	14			
03	00:00:07	10			
04	04:30:00	10			
05	00:01:00	ATM	✓		
06	00:00:32	75			
07	00:00:00	75			
08	00:00:00	75			
09	00:00:00	75			
10	00:00:00	75			
----- zurück -----					
04:36:37					

5. Store the program under a free program number.

¹ Not usable for mode VACUULAN.

7.2.6 Program examples

Example 1

Example 1

Program					
No	hh:mm:ss	Vac	Vent.	Step	Auto
01	00:03:00	500			
02	00:00:00	0			
03	00:00:00	0			
04	00:00:00	0			
05	00:00:00	0			
06	00:00:00	0			
07	00:00:00	0			
08	00:00:00	0			
09	00:00:00	0			
10	00:00:00	0			
			back		
00:03:00					

Vacuum pump with in-line isolation valve:

Linear pump down to 500 mbar

N° Program step

- 01 Linear pump down to 500 mbar within 3 minutes. Limited reproducibility because of the undefined initial state.
- 02 -10 not used.

Example 2

Example 2

Program					
No	hh:mm:ss	Vac	Vent.	Step	Auto
01	00:00:00	ATM	✓	✓	
02	00:10:00	300		✓	
03	01:00:00	2			⊥
04	00:01:00	ATM	✓	✓	
05	00:00:00	0			
06	00:00:00	0			
07	00:00:00	0			
08	00:00:00	0			
09	00:00:00	0			
10	00:00:00	0			
			back		
01:11:00					

VARIO[®] pump with motor speed control connected to rotary evaporator:

Outgassing and automatic distillation with time presettings.

N° Program step

- 01 **ATM** = atmospheric pressure is set as reproducible initial state. The check marks at *Bel.* and *Step* are set automatically when **ATM** is selected.
- 02 Because of the check mark at *Step* the controller pumps down to 300 mbar as quickly as possible and holds vacuum level for 10 minutes at 300 mbar, e. g., solvent degassing.
- 03 The icon at *Auto* effects that the boiling vacuum will be automatically detected within the pressure interval from 300 mbar to 2 mbar. If the process varies, the boiling vacuum will be adapted automatically. The next program step starts after 60 minutes.

- 04 Because of the check mark at *Step* the controller is venting the system as quickly as possible to *ATM*. Control stops after 1 minute.
- 05 -10 not used.

Example 3

Example 3

Program					
No	hh:mm:ss	Vac	Vent.	Step	Auto
01	00:00:00	ATM	✓	✓	
02	00:05:00	10			
03	00:10:00	10			
04	00:01:00	500	✓		
05	00:09:00	500	✓		
06	00:10:00	5			
07	00:20:00	5			
08	00:01:00	ATM	✓	✓	
09	00:00:00	0			
10	00:00:00	0			
----- back -----					
00:56:00					

Vacuum pump with in-line isolation valve and/or Vacuum Management System VMS B:
 Pump down with intermediate venting

N° Program step

- 01 *ATM* = atmospheric pressure is set as reproducible initial state.
- 02 Pump down within 5 minutes from *ATM* to 10 mbar (linear ramp).
- 03 Hold vacuum level for 10 minutes at 10 mbar.
- 04 Venting within 1 minute from 10 mbar to 500 mbar.
- 05 Hold vacuum level for 9 minutes at 500 mbar.
- 06 Pump down within 10 minutes from 500 mbar to 5 mbar.
- 07 Hold vacuum level for 20 minutes at 5 mbar.
- 08 Because of the check mark at *Step* the controller is venting the system as quickly as possible to *ATM* = atmospheric pressure. Control stops after 1 minute.
- 09 -10 not used.

7.2.7 Sample form for program

IMPORTANT! When loading the factory settings, the data stored in the program memory will be deleted.

⇒ Keep important program settings and make note of the values that are listed in the program editor.

Program		N°: <input style="width: 100px; height: 20px;" type="text"/>			
No	hh:mm:ss	Vac	Vent.	Step	Auto
01	____:____:____	_____	<input type="checkbox"/>	<input type="checkbox"/>	<input type="checkbox"/>
02	____:____:____	_____	<input type="checkbox"/>	<input type="checkbox"/>	<input type="checkbox"/>
03	____:____:____	_____	<input type="checkbox"/>	<input type="checkbox"/>	<input type="checkbox"/>
04	____:____:____	_____	<input type="checkbox"/>	<input type="checkbox"/>	<input type="checkbox"/>
05	____:____:____	_____	<input type="checkbox"/>	<input type="checkbox"/>	<input type="checkbox"/>
06	____:____:____	_____	<input type="checkbox"/>	<input type="checkbox"/>	<input type="checkbox"/>
07	____:____:____	_____	<input type="checkbox"/>	<input type="checkbox"/>	<input type="checkbox"/>
08	____:____:____	_____	<input type="checkbox"/>	<input type="checkbox"/>	<input type="checkbox"/>
09	____:____:____	_____	<input type="checkbox"/>	<input type="checkbox"/>	<input type="checkbox"/>
10	____:____:____	_____	<input type="checkbox"/>	<input type="checkbox"/>	<input type="checkbox"/>
-----		back	-----		
	____:____:____				

7.3 Configuration menu

Meaning In menu **Configuration** the controller parameters are set. This menu is also for adjusting the vacuum sensor and for loading **Defaults** settings.

Call up Configuration menu

→ Example
Call up
Configuration menu

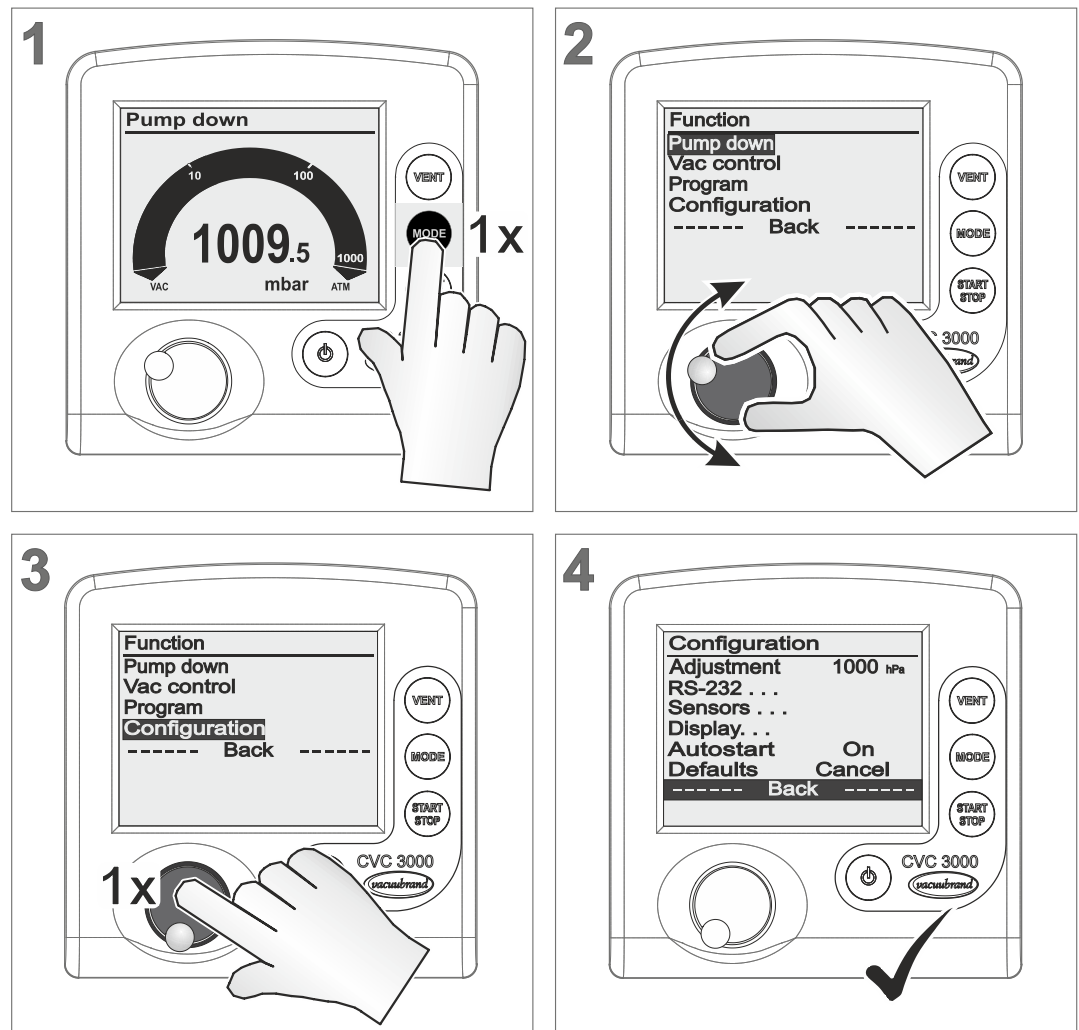

Configuration menu displayed.



After 20 seconds without action, the display will return automatically to pressure display.

7.3.1 Content selection

Specified content The following menu items of **Configuration** can be selected, activated and used.

Defaults

Defaults (standard)

Selection	Meaning
Cancel	Leave menu item without default setting.
Load	Load default settings.

IMPORTANT!

If **Defaults Load** is activated all controller parameter will be reset to delivery status. Stored programs will be deleted.

Autostart

Auto start function

Selection	Meaning
Off	After switching on power supply or after power failure the controller remains in <i>Stop</i> . Press Start/Stop key to start the controller.
On	Once power is applied, the controller starts automatically with the settings before power failure. The controller starts control directly without pressing Start/Stop key, if it previously was in running operation. Recommended, if power supply is switched on from a central point or if power is switched on by an external switch.

IMPORTANT!

Ensure, if **Autostart** is activated, that no hazardous situations may occur due to the automatic start of the process.

⇒ Check whether the **Autostart** feature can be used safely with the intended application.

Adjustment

Sensor adjustment function

Selection	Meaning
1060–700 20–0	Adjustment range of a vacuum sensor, internal or external at atmospheric pressure (1060–700) or under vacuum (20– ~0).

For further descriptions about sensor adjustment
 → see chapter: **9.2 Sensor readjustment**

7.3.2 Submenus

Submenu – Display

Submenu Display

Display	
Brightness	100 %
Contrast	40 %
Sound	On
Units	mbar
Language	English
----- back -----	

Adjustable display parameter

Parameter	Selection	Meaning
Brightness	0–100 %	Adjust backlight brightness of the display.
Contrast	0–100 %	Adjust display contrast.
Sound	Off	Switch off keystroke sound and warning sound.
	On	Switch on keystroke sound and warning sound.
Units	mbar	Preset pressure unit for user interface.
	Torr	
	hPa	
Language	14 languages available	Select language for user interface.

Submenu – Sensors

In submenu *Sensors* all connected sensors² are listed. The internal sensor is generally displayed as *Sensor*. External sensors are listed with sensor type name and address.

Submenu Sensors

Sensors	
Sensor	990.8 mbar
VSP 1	4.1E+2 mbar

Sensor selection

Display	Meaning
Inverse	Sensor = currently selected for pressure display.
Sensor type	Selection for displaying pressure on basic display (max. 8 sensors are listed).



The display switches automatically to the previous menu when selecting a sensor with the selection knob.

For descriptions about sensor address assignment

→ see chapter: *7.4.2 Submenu Vacuubus (address assignment)*

² -> Reference sensors are not listed in the Sensor menu, but deducted directly from the corresponding VSK sensor.

Submenu – RS-232

Submenu *RS-232* is applied for interface configuration, parameter adjustments and commands.

→ see also chapter: *10.2 Interface commands*.

Submenu RS232

RS-232	
Baud	19200
Parity	8-N-1
Handshake	None
Remote	Off
----- back -----	

Adjustable RS232 parameter

Parameter	Selection	Meaning
Baud	19200	Default setting for transmission speed. The baud rate of data transfer of transmitter and receiver must correspond.
	9600	
	4800	
	2400	
Parity	8-N-1	Default setting for parity check, a method for error detection
	7-O-1	
	7-E-1	
Handshake	RTS-CTS	Preset for continuous data transmission without loss – flow control.
	Xon-Xoff	
	None	
Remote	Off	Control commands not enabled, only queries possible
	On	Connection for communication via RS 232 interface enabled.

IMPORTANT!

When selecting *Remote On* the controller itself is only operable via an external device. All keys of the control panel except key *On/Off* are locked.

VACUU·CONTROL® detects automatically, if *Remote* is activated or deactivated and retains that setting.

Icon on controller display

Icon	Meaning
	PC icon? Controller in remote operation!

7.4 Function menu

Meaning **Function** menu is not for every day use but for special controller parameters, like **VACUU-BUS®** address assignment or updates.

Call up Function menu

→ Example
Call up
Function menu

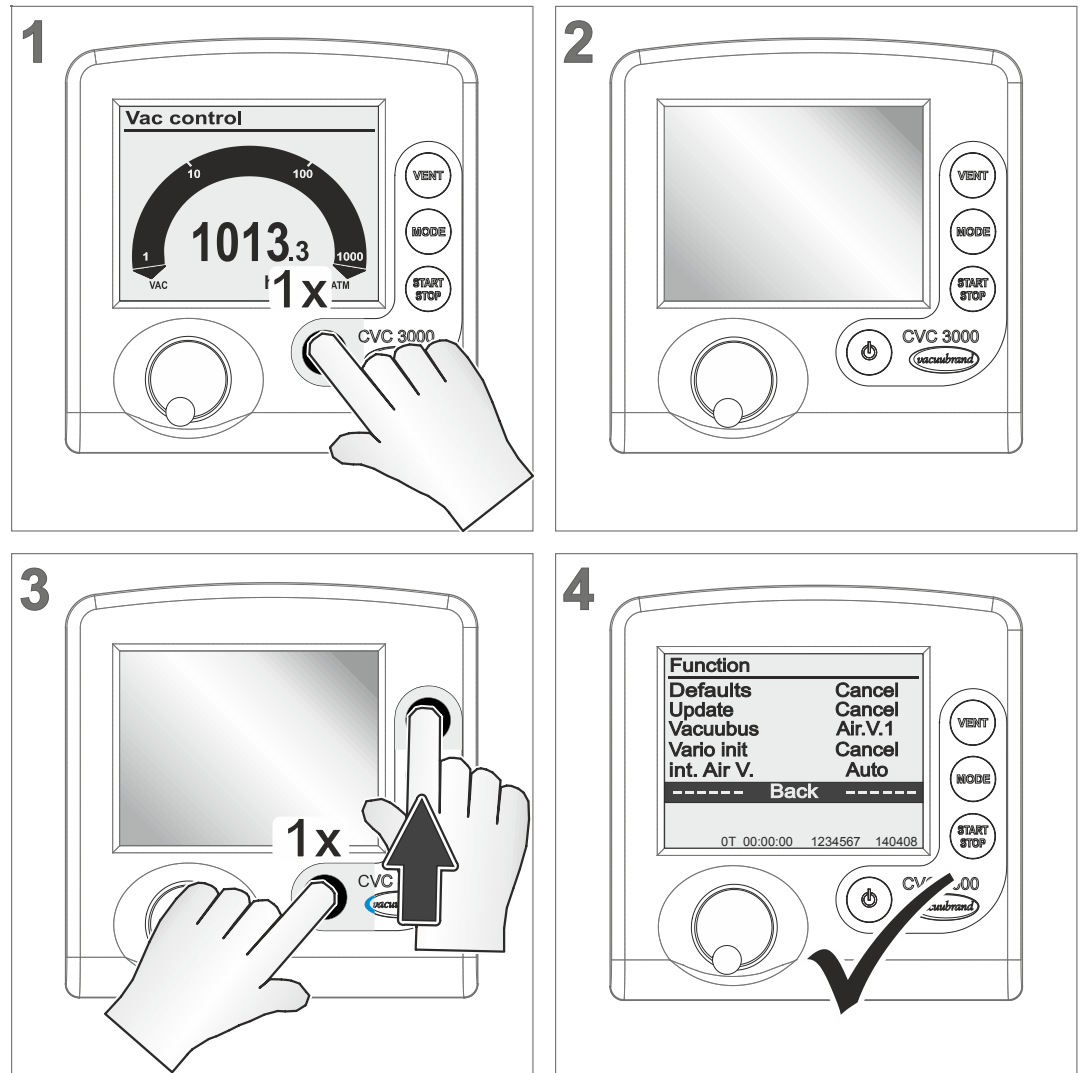

Function menu displayed.

7.4.1 Content selection

Specified content The following menu items of **Function** can be selected and/or loaded.

int. Air V.

Internal air admittance valve (venting valve)

Selection	Meaning
Auto	Internal venting valve does not switch, if an external venting valve or vacuum sensor is connected to the controller.
Off	Internal venting valve deactivated. Venting function is cannot be controlled. VENT key is switched off.
On	Internal venting valve does switch, even if an external venting valve or vacuum sensor is connected to the controller. VENT key is switched on.

IMPORTANT!

When **Venting** with inert gas ensure that inert gas is connected to all venting valves to prevent intruding air.

Vario init

Initialize frequency converter

Selection	Meaning
Cancel	Quit menu item without initialization.
NT	Initialization for 2/4 or 8 head NT VARIO diaphragm pump and transferring motor parameter.
Star	Initialization for 8 head VARIO-B diaphragm pump.

IMPORTANT!

Use this function only after the exchange of a frequency converter. Wrong motor parameters may cause motor overheating or bad pumping speed performance.

⇒ Only select motor parameter that is suitable for the vacuum pump.

The set of motor parameters will only be transmitted with the correct key combination.

⇒ Press and hold **Mode** key + press **Selection knob**.

Succeed appears on the display.

Update

Firmware update

Selection	Meaning
Cancel	Quit menu item without updating.
Load	Load controller firmware update.

Defaults³

Default settings for Service

Selection	Meaning
Cancel	Quit menu item without default setting.
Normal	Load default settings – including presettings for 1–3 stage VARIO [®] pumps or for pumping units or for table top controller with 2-point control. Presetting: Mode <i>Vac control</i> Set vacuum: 100 mbar
Turbo	Load default settings – including presettings for 4 stage VARIO [®] pumps used as backing for turbomolecular pumps. Presetting: Mode <i>Vac control</i> Set vacuum: <i>Turbo</i>
VCL	Load default settings – including presettings for pumping units with built-in controller or for VACUU·LAN with built-in controller. Presetting: Mode <i>VACUULAN</i> Set vacuum: 25 mbar

IMPORTANT!

This type of *Defaults* factory setting resets all controller parameters back to a special pre-configured delivery state.

These factory settings are reserved only for our service technicians.

⇒ Use factory setting in **Configuration** menu.

³ -> Characteristic: When loading **Defaults** in **Function** menu, firstly **Succeed** is displayed, then the language selection appears on the display.

7.4.2 Submenu Vacuubus (address assignment)

NOTICE
VACUU·BUS® components always need to be configured, if several components of the same type are to be connected, e.g., 3 external sensors VSK type. Configuration is equivalent to address assignment.

Address assignment (configuration)

Meaning Several **VACUU·BUS®** components of the same type, which are connected to the controller, each require an individual address code for correct communication. On delivery state each **VACUU·BUS®** component has the default address 1.

The controller requires the address information to differentiate between identical **VACUU·BUS®** components and for communication. To change address use menu *Function/Vacuubus*.

Example: VACUU·BUS® addresses

→ Example
Assigned address numbers

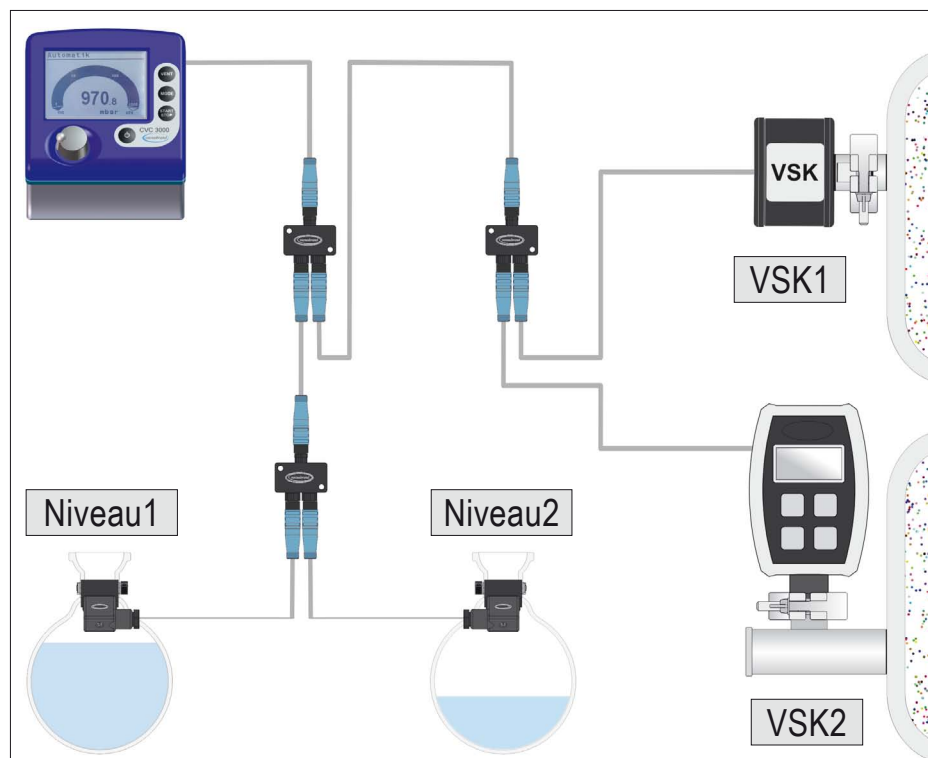

Controller (internal sensor VSK type) + 2x external sensor
 + 2x Level sensor

- ▶ New address assignment for the second level sensor and the second external VSK sensor.

Assign a new address number to a VACUU-BUS® component

In the following example a second VSK type sensor receives **VSK2** as new communication address code.

IMPORTANT!

A new address can be assigned **only individually**.

⇒ Connect only the **VACUU-BUS®** component to the controller, which requires a new address.

⇒ If an address assignment for several **VACUU-BUS®** components of the same type is necessary, then connect and address them individually and one after the other.

→ Example
Assignment for VSK

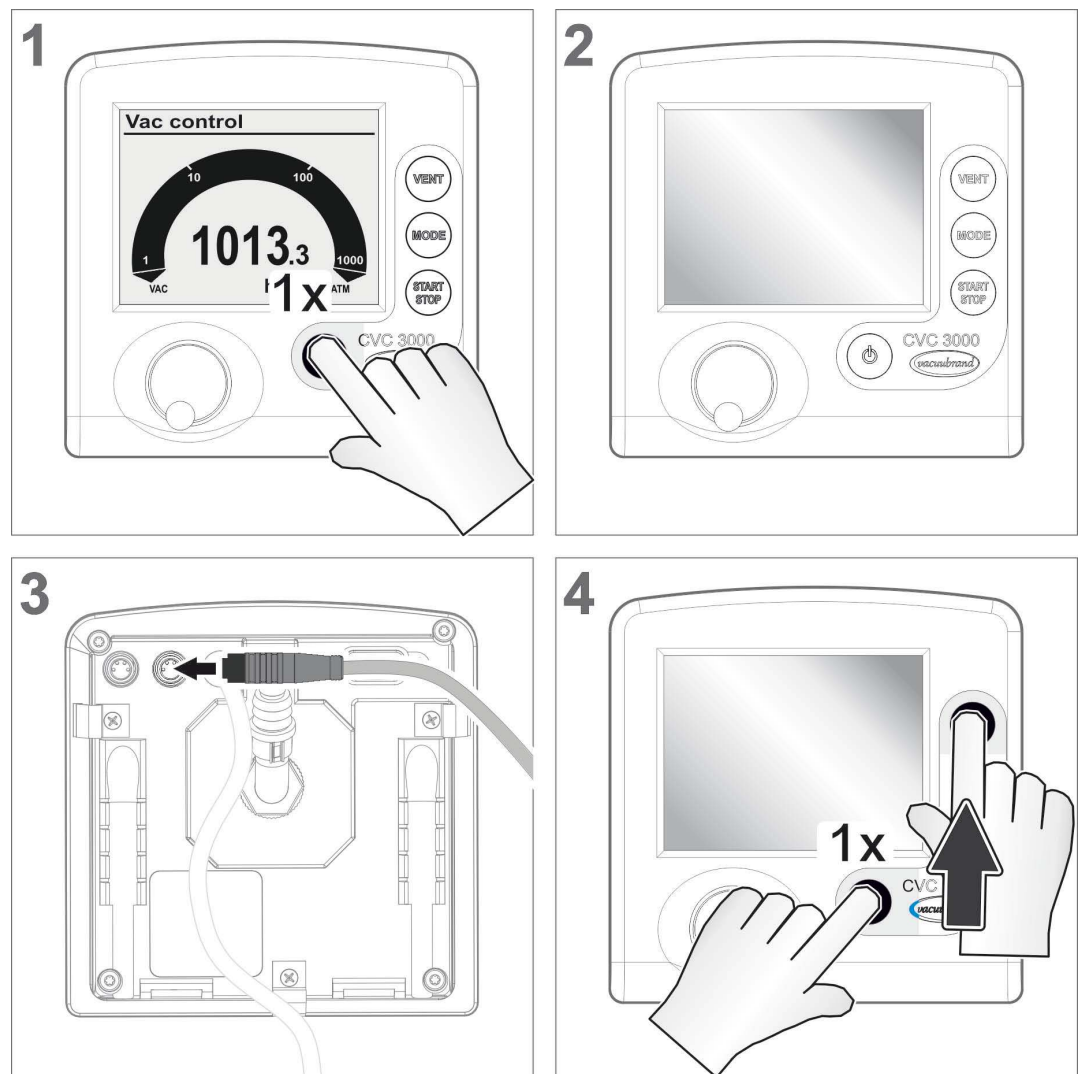

→ Example
VACUU-BUS
assignment

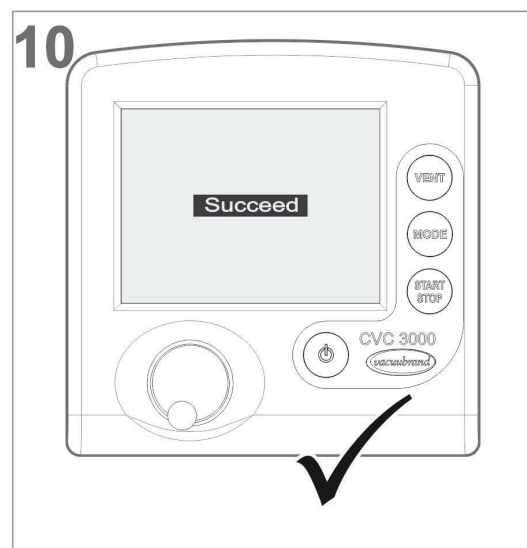
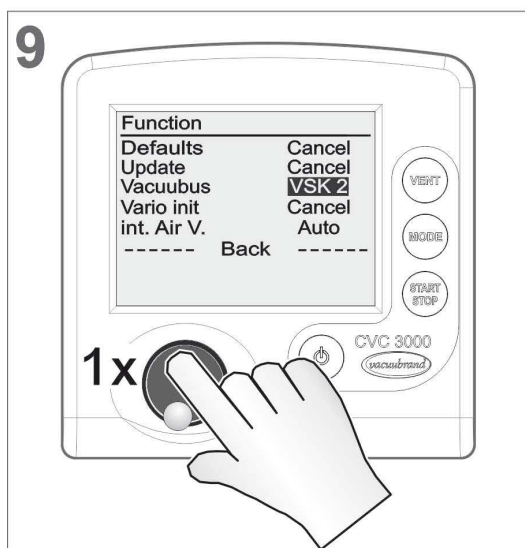
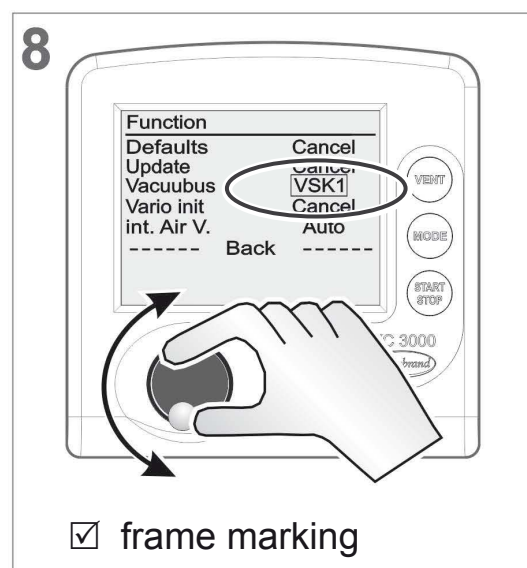
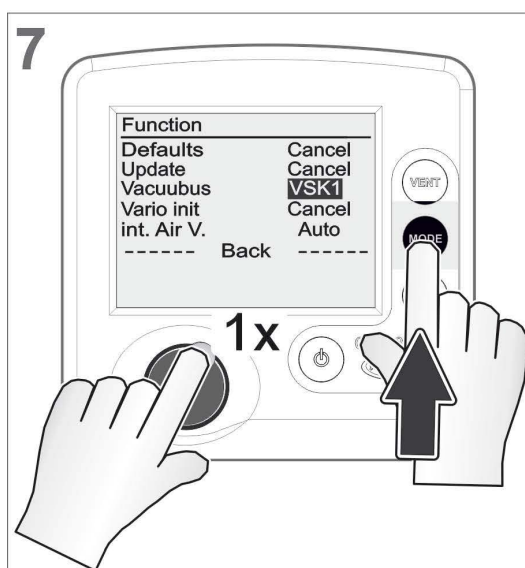
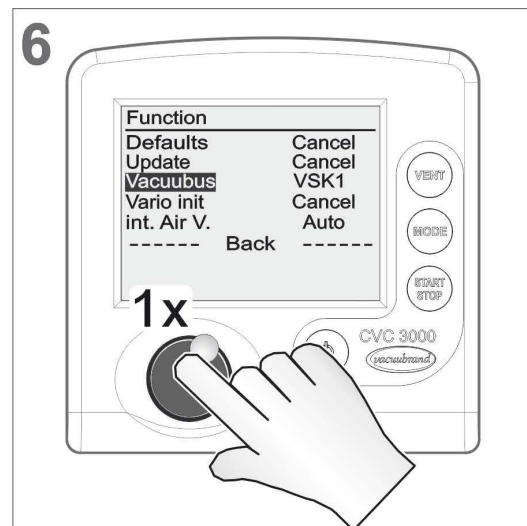
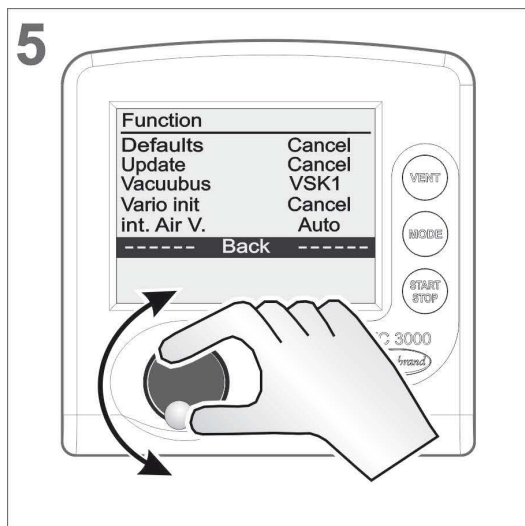

☑ New communication address code for second sensor
VSK = **VSK2**

7.4.3 Possible address configurations

Address table
VACUU·BUS
components

VACUU·BUS elements	**Address N°	Abbreviation
In-line suction valve	1–4	Isol.v. _
Coolant valve	1–4	Waterv. _
Venting valve (air admittance valve)	1–4	Air V. _
VMS module	1–4	VMS _
Fault indicator	1	Error
Remote module	1	Remote
A valve that opens at the end of the process	1–2	End
Not in use	---	Reserved
Level sensor	1–4	Level _
Reference sensor VSK 3000, VACUU·VIEW	1–4	Ref. _
Vacuum sensor VSK 3000, VACUU·VIEW	1–4	VSK _
Vacuum sensor VSP 3000, VACUU·VIEW extended	1–4	VSP _
*Output actual vacuum	1	Vacuum
*Output actual speed	1	Speed
*Input set vacuum and output actual vacuum	1	Set vac
*Input set speed and actual speed	1	SetSpeed
***ATEX-VARIO pump [1500 rpm]	1–3	ATEX _
***Basic configuration Ex; with ATEX VARIO pump [1500 rpm] and Ex sensor	-	ATEX I/O
NT VARIO pump, from 2015 [2400 rpm]	1–4	VarioX _
PC 3001	1–8	Var-SP _
EK Peltronic	1–3	Pelt. _
Not in use	---	Reserved
NT VARIO pump	1–8	Vario _

* Analog I/O module (0–10 V/0–10 V)

** = Number of addresses that can be assigned maximally

*** Analog I/O module (4–20 mA/0–10 V)



The scope of the listed Vacuubus components depends on the firmware version of your controller.

7.5 Differential pressure measurement

Meaning A differential pressure between two pressure sensors can be determined and displayed between the internal pressure sensor and an external sensor⁴ or between two external sensors⁴ → see chapter: 7.4.2 Submenu *Vacuubus (address assignment)*. Mode **Vac control** controls automatically to the differential pressure, if the sensor **VSK..** is selected as active sensor in submenu **Sensors...** .

Prepare the internal sensor and one external VSK sensor

Prepare sensors

1. Connect an external VSK type sensor to the controller.
2. Assign the address **Ref.1** for that external sensor.

IMPORTANT!

For differential pressure measurement between the internal sensor and the external sensor, no further sensor with address **VSK1** must be connected.

⇒ Assign other address numbers for additionally connected VSK sensors → see 7.4.2.

Prepare two external VSK sensors

1. Connect two external sensors VSK type to the controller.
2. Assign address **VSK1** to one of the sensors.
3. Define the second sensor as reference sensor by assigning address **Ref.1** to it.

IMPORTANT!

If address 1 has already been assigned, you should assign the next free address numbers, e. g., **VSK2** and **Ref.2** to the sensors.

The differential pressure is only determined between sensors with corresponding address numbers.

Measuring differential pressure

Measuring differential pressure

- ⇒ Start the controller.
- Pressure display displays differential pressure: reference sensor *minus* VSK sensor.

4 -> VSK 3000 or VACUU·VIEW

8 Resolving problems

Technical support

Technical support ⇒ To identify errors and potential remedies, please refer to the troubleshooting table: *Fault – Cause – Remedy*.



In case you need additional assistance, please contact our [Service](#) department.

8.1 Error display

The major symbol for fault indication is the warning triangle. Additionally displayed icons and sounds refer to the cause of fault.

Safety alert symbol

Warning triangle

Icon	Meaning
	Flashing: Warning! Where applicable with: <ul style="list-style-type: none"> flashing component icon, warning sound (only when switched on) or flashing backlight.
	<ul style="list-style-type: none"> in combination with number = VACUU·BUS address of the component which is defective.





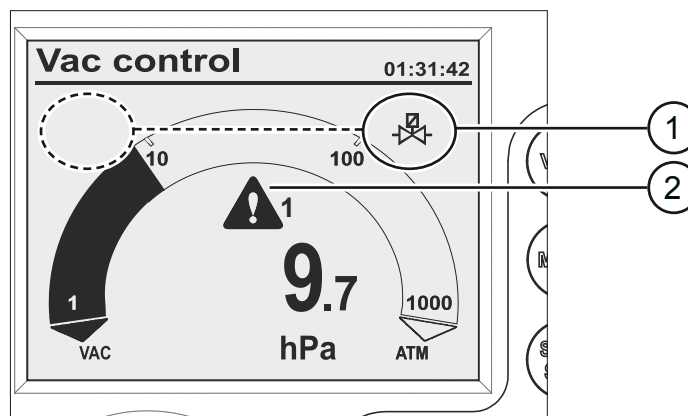





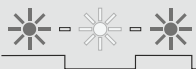





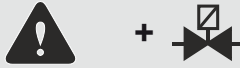

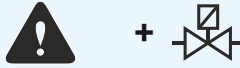



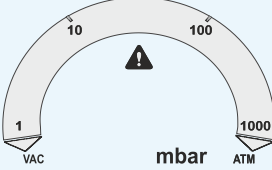

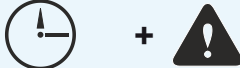

Example display in case of error

→ Example
Error In-line valve 1

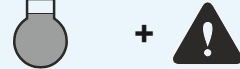

- 1 Possible positions for flashing component/display icon; here: warning In-line valve
- 2 Flashing: Warning triangle

Combinations of flashing display icons

Icon flash rate 	Fault and Meaning	beep when Sound On
	▶ Limit pressure reached	1x 
	▶ Overpressure	1x 
	▶ Process time elapsed	1x 
	▶ Venting valve	2x 
	▶ In-line suction valve	3x 
	▶ Coolant valve	4x 
	▶ External sensor removed ▶ or defective	5x 
	▶ internal sensor defective	7x 
	▶ Vario pump	6x 
	▶ VACUULAN process pressure not reached within 99 hours.	8x 
	Digital I/O module: ▶ Fault indicator triggered or ▶ fault special configurations	9x 
	▶ Level sensor triggered; flask full	10x 
	▶ Emission condenser Peltronic (too hot)	11x 
	▶ Analog I/O module	12x 



A defective I/O module, which is configured as a remote module, does not trigger a warning alert. The control is stopped. Alert display by the flashing warning triangle.

8.2 Fault – Cause – Remedy

Fault	Possible cause	Remedy	Personnel
Sensitive process not controllable	<ul style="list-style-type: none"> ▶ Motor speed too high. ▶ Pumping speed too high. 	<ul style="list-style-type: none"> ✓ Reduce motor speed. 	User, Specialist
Frequent error messages of connected components	<ul style="list-style-type: none"> ▶ Several controllers are connected. ▶ Several VACUU·BUS components of the same type are using the same address. 	<ul style="list-style-type: none"> ✓ Use only one controller for one VACUU·BUS system. ✓ Assign individual addresses in menu <i>Function/ Vacuubus</i> to components of the same type. 	respon. Specialist
VENT key does not work	<ul style="list-style-type: none"> ▶ <i>Venting</i> function deactivated. 	<ul style="list-style-type: none"> ✓ Check why <i>Venting</i> is deactivated. 	Specialist, respon. Specialist
Internal air admittance valve cannot be triggered	<ul style="list-style-type: none"> ▶ In menu <i>Function</i>, setting of <i>int.Air V</i> is switched <i>Off</i> or <i>Auto</i>. ▶ External air admittance valve is connected, <i>and/or</i> ▶ external vacuum sensor is connected. 	<ul style="list-style-type: none"> ✓ Check if <i>Venting</i> by internal air admittance valve can be used without risk. ✓ <i>Venting safe?</i> Enable the function in menu <i>Function/ int.Air V</i>; adjustment: <i>Auto</i> or <i>On</i>. 	Specialist, respon. Specialist
Internal air admittance valve does not switch	<ul style="list-style-type: none"> ▶ Air admittance valve is soiled. 	<ul style="list-style-type: none"> ✓ Clean air admittance valve, see description in chapter 9.1 <i>Cleaning</i> 	Specialist
Function or menu item cannot be used	<ul style="list-style-type: none"> ▶ Function or menu item possibly only usable with shortcut (key combination). 	<ul style="list-style-type: none"> ✓ Press the correct key combination; for descriptions of keys and shortcuts see chapter: 5.1 <i>Operating elements</i> 	Specialist, respon. Specialist
Vario pump icon flashes	<ul style="list-style-type: none"> ▶ VARIO pump and VMS are both connected at the same time. ▶ VARIO pump defective. ▶ VMS defective or cable is not connected. ▶ Cable break. 	<ul style="list-style-type: none"> ✓ Remove VMS from VARIO-pump and restart controller. ✓ Check VARIO pump for defective parts. ✓ Check VMS for defective parts. ✓ Check cable connections. ✓ Replace defective parts. 	Specialist
Air admittance valve icon flashes	<ul style="list-style-type: none"> ▶ External air admittance valve removed. ▶ Plug disconnected. ▶ External air admittance valve defective. 	<ul style="list-style-type: none"> ✓ Check the connection. ✓ Check plug connection. ✓ Replace defective parts. ✓ Use internal air admittance valve. ✓ Reconfiguration without air admittance valve. 	Specialist

Fault	Possible cause	Remedy	Personnel
In-line suction valve icon flashes	<ul style="list-style-type: none"> ▶ In-line suction valve removed. ▶ Plug disconnected. ▶ In-line suction valve defective. 	<ul style="list-style-type: none"> ✓ Check the connection. ✓ Check plug connection. ✓ Replace defective parts. ✓ Reconfiguration without In-line suction valve. ✓ Switch-off the controller; On/Off key. ✓ Remove In-line suction valve and ✓ switch on controller again. 	User, Specialist
Coolant valve icon flashes	<ul style="list-style-type: none"> ▶ Coolant valve removed. ▶ Coolant valve defective. 	<ul style="list-style-type: none"> ✓ Check the connection. ✓ Replace defective parts. ✓ Reconfiguration without coolant valve. 	Specialist
Level sensor icon flashes	<ul style="list-style-type: none"> ▶ Level sensor triggered (flask full). ▶ Level sensor removed. ▶ Level sensor triggered with empty flask. ▶ Cable break. ▶ Level sensor defective. 	<ul style="list-style-type: none"> ✓ Empty flask/catch pot. ✓ Check position of level sensor. ✓ Adjust level sensor or delete the sensor from controller (by loading default). ✓ Check plug connection. ✓ Replace defective parts. 	Specialist
Peltronic icon flashes	<ul style="list-style-type: none"> ▶ Peltronic emission condenser too hot. ▶ Plug disconnected. 	<ul style="list-style-type: none"> ✓ Let the Peltronic emission condenser cool down. ✓ Check plug connection. 	User, Specialist
Title bar without text	<ul style="list-style-type: none"> ▶ No controllable device connected (In-line suction valve, VMS, VARIO pump). 	<ul style="list-style-type: none"> ✓ Check device connections and cable. ✓ Replace defective parts. ✓ Connect a controllable device to the controller. ✓ Use the controller as measuring gauge. 	Specialist
No key reaction – only On/Off, PC icon displayed	<ul style="list-style-type: none"> ▶ Remote switched On. ▶ Controller only controllable via connected external end device (via RS232). 	<ul style="list-style-type: none"> ✓ Switch-off Remote (in menu Configuration/RS232 switch Remote Off). ✓ Control controller via end device like PC. 	Specialist
No reaction to key actuation	<ul style="list-style-type: none"> ▶ Controller defective 	<ul style="list-style-type: none"> ✓ Contact Service and ✓ return device for repair. 	respon. Specialist

Fault	Possible cause	Remedy	Personnel
No display	<ul style="list-style-type: none"> ▶ Controller switched off. ▶ Power supply disconnected. ▶ Power supply not correctly connected. ▶ Mains voltage failure. ▶ Controller defective. ▶ Cable break. 	<ul style="list-style-type: none"> ✓ Switch on the controller; On/Off key. ✓ Check plug connection and wall power supply for correct connection. ✓ Replace defective parts. ✓ Contact Service and ✓ return device for repair. 	Specialist
Blank display	<ul style="list-style-type: none"> ▶ Too many devices connected, e. g., valves. 	<ul style="list-style-type: none"> ✓ Power input of all connected devices may not exceed the maximum power consumption of the controller: <ul style="list-style-type: none"> - controller with wall power supply max. 30 W, - controller + VARIO max. 25 W. 	respon. Specialist
	<ul style="list-style-type: none"> ▶ Short circuit of a connected device. 	<ul style="list-style-type: none"> ✓ Replace defective parts. 	
	<ul style="list-style-type: none"> ▶ Short circuit at RS232 interface. ▶ Controller defective. 	<ul style="list-style-type: none"> ✓ Check RS232 plug connection. ✓ Contact Service and ✓ return device for repair. 	
Incorrect pressure display	<ul style="list-style-type: none"> ▶ Humidity inside the vacuum sensor. ▶ Vacuum sensor soiled. ▶ Vacuum sensor not adjusted. ▶ Vacuum sensor not correctly adjusted. 	<ul style="list-style-type: none"> ✓ Identify and remove source of humidity. ✓ Dry the vacuum sensor, e. g., by pumping down. ✓ Clean the vacuum sensor, see <i>chapter 9.1 Cleaning</i>. ✓ Readjust vacuum sensor. 	User, Specialist
Digital pressure gauge flashes	<ul style="list-style-type: none"> ▶ Pressure display flashing with 0.0: <ul style="list-style-type: none"> - vacuum adjustment not correctly carried out. ▶ Pressure display flashing: <ul style="list-style-type: none"> - Overpressure! Pressure > 1060 mbar. 	<ul style="list-style-type: none"> ✓ Readjust internal or external vacuum sensor, see <i>chapter 9.2 Sensor readjustment</i>. <p>⚠ WARNUNG! Risk of bursting. ⇒ Discharge the system immediately by venting.</p>	Specialist
No digital pressure reading	<ul style="list-style-type: none"> ▶ External vacuum sensor defective. ▶ External vacuum sensor removed. ▶ Internal vacuum sensor defective. 	<ul style="list-style-type: none"> ✓ Replace defective parts. ✓ Reconnect external vacuum sensor. ✓ Contact Service and ✓ return device for repair. 	respon. Specialist

Fault	Possible cause	Remedy	Personnel
Sensors submenu is permanently displayed	▶ Submenu <i>Sensors...</i> does not automatically switch back to previous display.	✓ Select the required sensor by turning and pressing selection knob.	User, Specialist
After loading defaults <i>Language selection</i> appears	▶ Special factory settings have been loaded.	✓ Set language and pressure unit. IMPORTANT: Check if the loaded default settings are suitable for your vacuum apparatus. Compare <i>Content selection</i> in chapter: 7.4.1	respon. Specialist
Error I/O module	▶ Plug disconnected. ▶ An error occurred in the system, the I/O module passed the error alert to the controller.	✓ Check plug connection. ✓ Remedy external fault.	Specialist, respon. Specialist
VSP sensor displays wrong values	▶ VSP sensor configured as VSK.	✓ Use menu <i>Function/Vacuubus</i> to reconfigure the sensor as VSP.	Specialist, respon. Specialist
Controller in operation, pressure display flashes	▶ VSK sensors are measuring negative difference pressure.	✓ Select an other vacuum sensor in menu <i>Sensors</i> .	User, Specialist

Action required	Cause	Remedy
Process time elapsed	▶ All program steps are completed. ▶ Program end reached.	✓ Acknowledge indication by pressing Start/Stop key.
Flashing clock icon	▶ Process time elapsed.	✓ Acknowledge indication by pressing Start/Stop key.
Pump down stops, blinking arrow down icon	▶ Pressure below preset minimum value.	✓ Acknowledge indication by pressing Start/Stop key. ✓ If possible readjust presetting (Min.).
Vac control stops, flashing arrow up icon	▶ Preset maximum value exceeded.	✓ Acknowledge indication by pressing Start/Stop key. ✓ If possible readjust presetting (Max.).
Program -	▶ Program not yet stored.	✓ Store program under a free program number.

8.3 Controller Reset

Auto reset

Automatic reset The following error indications will be reset automatically with remedy:

- Overpressure
- Process time elapsed
- Limit pressure reached
- Error air admittance valve
- Error Peltronic

Active reset

Reset after action Several error indications need to be reset manually. Depending on the fault severity different actions are required.

⇒ Press **Start/Stop** key to reset the following error indications:

- In-line suction valve error
- Coolant valve error
- External vacuum sensor removed
- I/O module activated **Error indication**
- external error indicator has triggered via Digital I/O module; assigned as **Error**.
- Level sensor triggered

⇒ Load **Defaults** (standard factory setting) to reset the following error indications:

- Missing set value presetting or VACUU·BUS plug disconnected via Digital I/O module; assigned as **Remote**.
- Level sensor removed and/or VACUU·BUS plug disconnected.

→ see also chapter: **7.3 Configuration menu** for loading **Defaults**

IMPORTANT! ⇒ Note the settings of stored programs, before loading *Default*.

Load *Default* settings

Load factory settings

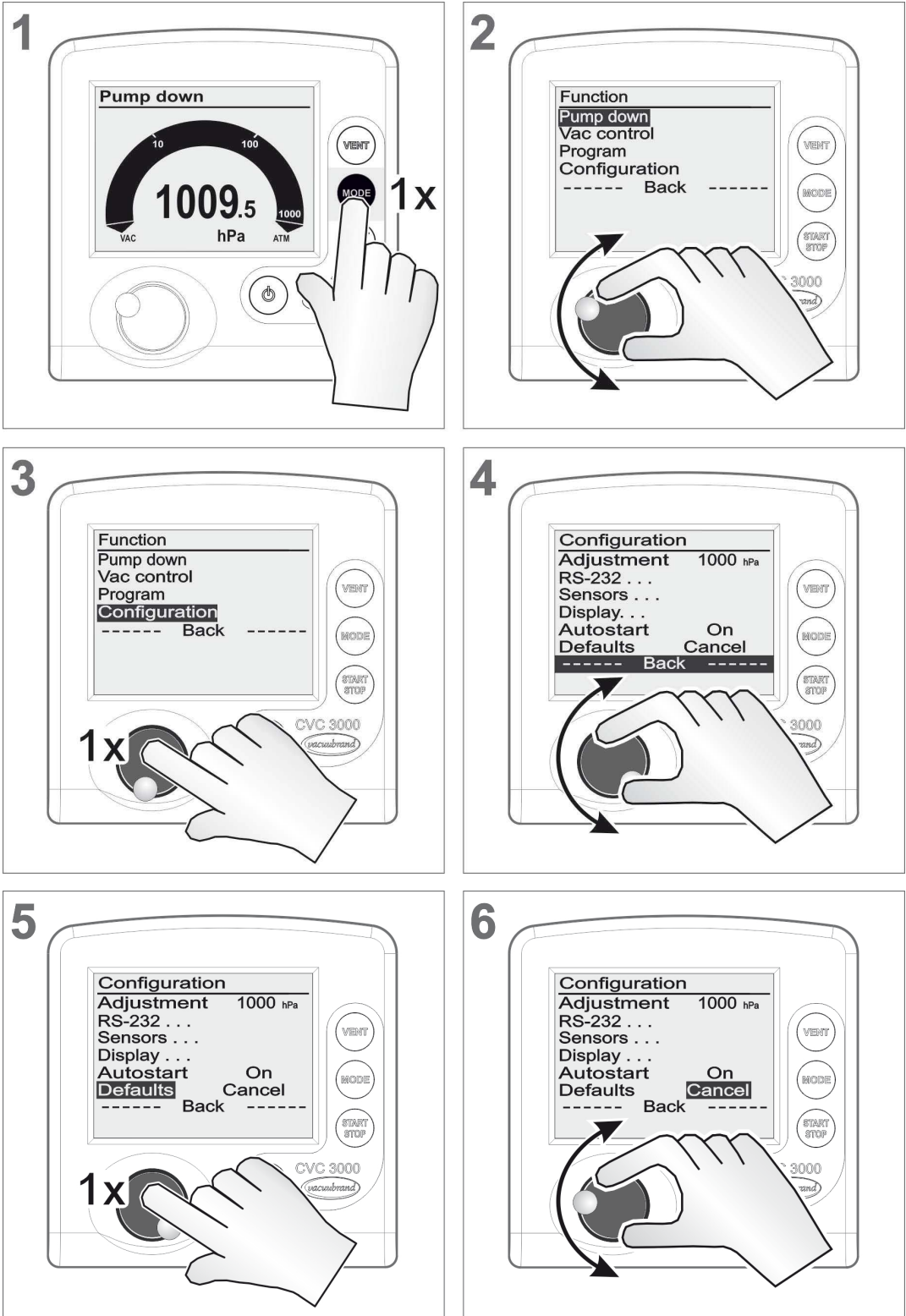

Load factory settings

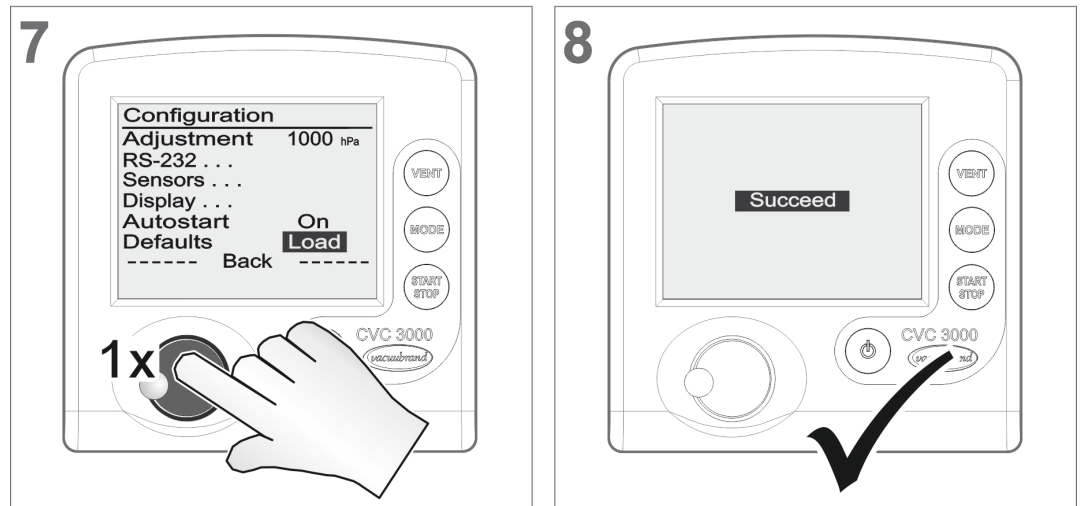

8.4 Error of external components

Error messages for defective external components such as In-line suction valve, vacuum sensor, etc. cannot be reset.

⇒ Replace defective accessories or

⇒ send defective accessories for repair to your local supplier or to our [Service](#).

9 Cleaning and maintenance

9.1 Cleaning

IMPORTANT!

This chapter does not contain descriptions for the decontamination of the controller. This chapter describes only simple cleaning and care measures.

9.1.1 Controller

Clean surface



⇒ Clean soiled surface with a clean, slightly wetted cloth. To moisten the cloth we recommend water or mild soap.

9.1.2 Venting valve

Clean venting¹ valve

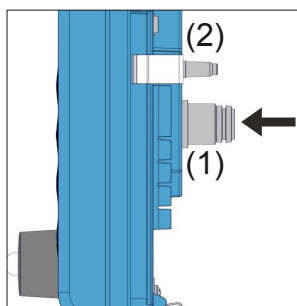

1. Apply slight overpressure of dry air or inert gas to the vacuum port (1).
2. Press the **VENT** key several times until gas escapes through the venting port (2).
3. Repeat this procedure until you hear the clicking of the valve and a gas stream is noticeable at the venting port (2).

9.1.3 Internal sensor

Clean internal sensor

1. Fill a small amount of solvent via the vacuum port (1) in the controller, e. g., cleaning solvent.
2. Let the solvent react for a few minutes.
3. Drain the solvent.
 - ☑ Dissolved substances or discolorations in the solvent are possible.
4. Repeat this procedure until no more pollutants are in the solvent.
5. Let the controller dry.
6. Readjust the internal (vacuum) sensor.

¹ -> air admittance valve

9.2 Sensor readjustment

NOTICE

For readjustment the reference pressures need to be known with certainty

In the pressure range 20 – 700 mbar (15 – 525 Torr) no adjustment is possible.

- ⇒ Check the accuracy of the pressure sensor in case of irregularities in the pressure display.
- ⇒ Readjust the sensor in two steps: at atmospheric pressure and under vacuum.

Do not adjust at atmospheric pressure, if the pressure at the location of the device is not exactly known (pay attention to height above sea level).

Any kind of pollution of the vacuum system, e. g., oil, substances, or humidity could falsify the adjustment.

- ⇒ Clean polluted sensors before readjustment.

Adjustment at atmospheric pressure

Adjustment at
atmospheric
pressure

An adjustment at atmospheric pressure is only possible if the pressure is higher than > 700 mbar (> 525 Torr).

1. Vent the measurement connection of the controller or in case the connected external vacuum sensor VSK 3000.
2. Make sure that the vacuum sensor (internal or external) is really at atmospheric pressure.
3. Determine the exact atmospheric pressure of your location, e. g., by barometer, inquiry at the meteorological office or the airport.
4. Call up menu **Configuration**.
5. Turn the **selection knob** and place the bar marking on **Adjustment**.
6. Press the **selection knob**.
 - Marking jumps to numeric value.
7. Adjust the exactly determined local atmospheric pressure by turning the **selection knob**.
8. Press the **selection knob**.
 - Sensor adjusted to atmospheric pressure.

Adjustment under vacuum

Adjustment under vacuum

An adjustment under vacuum is only possible if the pressure is lower than < 20 mbar (< 15 Torr) absolute.

1. Evacuate the measurement connection of the controller or in case the connected external vacuum sensor VSK 3000 to a pressure $< 0,1$ mbar.

IMPORTANT!

Adjustment under vacuum with an actual pressure higher than $0,1$ mbar (0.1 Torr) reduces the accuracy of the measurement. If the pressure is significantly higher than $> 0,1$ mbar (> 0.1 Torr) the adjustment to a reference pressure is recommended.

2. Call up menu **Configuration**.
3. Turn the **selection knob** and place the bar marking on **Adjustment**.
4. Press the **selection knob**.
 - Marking jumps to numeric value.
5. Adjust the pressure value to 0 by turning the **selection knob**.
6. Press the **selection knob**.
 - Sensor adjusted under vacuum.

NOTICE

The readjustment of a VSP 3000 can only be carried out in warmed-up state.

Adjustment is not possible during the warm-up time.

- ⇒ Use a high vacuum pump for the adjustment of a VSP sensor.
- ⇒ After connection to power supply and after the pressure has reached $< 10^{-3}$ mbar, wait 20 minutes before adjusting the VSP sensor.
- ⇒ Carry out the adjustment in the same order as described above for VSK.

Adjustment at a reference pressure

Adjustment at
reference pressure

Instead of adjustment under vacuum to a pressure $< 0,1$ mbar (< 0.1 Torr), adjustment to a precisely known reference pressure within the range of 0 – 20 mbar (0 – 15 Torr) is possible.

1. Evacuate the measurement connection of the controller or in case the connected external vacuum sensor VSK 3000 to a pressure in the range of 0 – 20 mbar (0 – 15 Torr).
2. Call up menu **Configuration**.
3. Turn the **selection knob** and place the bar marking on **Adjustment**.
4. Press the **selection knob**.
 - Marking jumps to numeric value.
5. Adjust the pressure value to the actual reference pressure by turning the **selection knob**.
6. Press the **selection knob**.
 - Sensor adjusted to reference pressure.

IMPORTANT!

The measurement uncertainty of the reference pressure will directly affect the measurement uncertainty of the controller.

If the nominal ultimate vacuum of a diaphragm pump is used as reference vacuum, the accuracy of the controller might be doubtful. The diaphragm pump may not achieve the specified vacuum (due to condensate, poor condition, failure of valves or diaphragm, leaks).

For further descriptions about **Adjustment**
→ see chapter: **7.3 Configuration menu**

10 Appendix

10.1 Technical information

Technical information

Product	
Vacuum controller	Vacuum Controller CVC 3000
Internal vacuum sensor	Ceramic diaphragm (alumina), capacitive, gas independent, absolute pressure

10.1.1 Technical data

Technical data

Ambient conditions		(US)
Working temperature	10–40 °C	50–104°F
Transport- and storage temperature	-10–60 °C	14–140°F
Altitude, max.	3000 m above sea level	9840 ft above sea level
Relative humidity	30–85 %, non condensing	
Avoid condensation or contamination by dust, liquids, or corrosive gases.		

Power supply unit		(US)
Input voltage	90–264 VAC	90–264 VAC
Frequency	47–63 Hz	47–63 Hz
Input current, max.	0,8 A	0.8 A
Output voltage, short-circuit-proof	24 VDC	24 VDC
Output current, max.	1,25 A	1.25 A
Cable length, approx.	2 m	79 in.
Dimension	108 mm x 58 mm x 34 mm 4.3 in. x 2.3 in. x 1.4 in.	
Weight	300 g	0.66 lb
Mains plug	AC, changeable: EU/UK/US/AUS	

Electrical data – CVC 3000		(US)
Supply voltage, max.	24 VDC (±10 %)	24 VDC (±10 %)
Power, max.	3,4 W	3.4 W
Max. admissible current total for connected valves	4 A	4 A
Degree of protection (controller front)	IP 20 (IP 42)	
Port (interface)	RS 232 SUB-D 9 poles	
Remote control, optional	VACUU·CONTROL®	

Technical data
basic device

Vacuum data		
CVC 3000, internal vacuum sensor		(US)
Measuring range, absolute	1080–0,1 mbar	810–0.1 Torr
Max. control range	1060–0,1 mbar	795–0.1 Torr
Resolution	0,1 mbar	0.1 Torr
Max. admissible media temperature (gas):		
Temporarily	80 °C	176°F
Continuous operation	40 °C	104°F
Measurement uncertainty	< ±1 mbar	< ±0.75 Torr
Temperature coefficient	< ±0,07 mbar/K	< ±0.05 Torr/K
External vacuum sensor VSK 3000		
Max. admissible pressure, absolute	1,5 bar	1125 Torr
Venting		
Max. admissible pressure, absolute	1,2 bar	900 Torr
Gas connections		
CVC built-in version	Fitting for PTFE tube 10/8 mm	
CVC table top version	Fitting for PTFE tube 10/8 mm or hose nozzle for flexible tube DN 6/10	
Venting	Hose nozzle for flexible tube $d_i = 4-5$ mm	

Technical data
package for fine
vacuum control

Vacuum data (only differing data)		
CVC 3000 with external VSP 3000		(US)
Measuring range, absolute	1000–1x 10 ⁻³ mbar	750–1x 10 ⁻³ Torr
Max. control range	1000–1x 10 ⁻³ mbar	750–1x 10 ⁻³ Torr
External vacuum sensor VSP 3000		
Max. admissible pressure, absolute	1,5 bar	1125 Torr
Cable, length	2 m	7 ft
Venting		
Max. admissible pressure, absolute	1,2 bar	900 Torr
without internal venting valve		

Technical data

Display		
Type	LC display (LCD)	
Brightness control	yes	
Pressure display	switchable: mbar, Torr, hPa	
Weight and dimensions*		
		(US)
Weight (built-in)	440 g	0.97 lb
Weight with foot (table top)	570 g	1.3 lb
Dimensions	123 mm x 124 mm x 83 mm 5 in. x 5 in. x 3.5 in.	
Dimensions with foot	144 mm x 124 mm x 115 mm 6 in. x 5 in. x 4.5 in.	

* without wall power supply

10.1.2 Product comparison CVC 3000

 Product comparison
CVC 3000

Product name	Vacuum controller	internal venting valve	external venting valve	internal vacuum sensor	external vacuum sensor	lower measuring limit (mbar)	Measuring principle - capacitive	Measuring principle - Pirani	Measuring principle - cold cathode	Measuring principle gas type independent	ATEX category 2	ATEX category 3 internal Atm. only
CVC 3000	✓	✓	x	✓	x	0.1	✓	-	-	✓	-	✓
CVC 3000 detect	✓	✓	x	✓	x	0.1	✓	-	-	✓	-	✓
CVC 3000 + VSK 3000	✓	✓	x	-	✓	0.1	✓	-	-	✓	-	✓
CVC 3000 + VSP 3000	✓	-	x	-	✓	1x 10 ⁻³	-	✓	-	-	-	-

x = optionally

10.1.3 Rating plate



- ⇒ In case of malfunction, please note type and serial number on the rating plate.
- ⇒ When contacting our [Service](#) department, name us product type and serial number. With this information we can offer selective support and advice for your product.

Rating plate CVC 3000

Rating plate

Manufacturer	VACUUBRAND GMBH + CO KG
Type/Date of construction/Month	CVC 3000 201 /0
Serial number	SN 12345678
Power supply	24 V
Electrical power	3.4 W
Compatible to VACUU-BUS	VACUU-BUS
ATEX spec *	II 3G IIC T3 X Internal Atm. only Tech File: VAC-EX01
Address	Alfred-Zippe-Str. 4 97877 Wertheim Made in Germany

- * Group and category, marking G (gas), type protection, explosion group, temperature class
(additionally see: [Approval for ATEX equipment](#)).

10.1.4 Wetted parts

Wetted parts

Component	Wetted materials
Vacuum connection, hose nozzle	PP
Sensor	Aluminium oxide ceramic
Sensor housing	PPS/Glasfaser
Sensor seal	chemically resistand fluoroelastomer
Venting valve seal	FPM

10.2 Interface commands

Short description
interface commands

The command set is based on NAMUR recommendations. In the delivery state it is fully compatible with the previous controller CVC 2000. Operation programs for CVC 2000 are able to communicate with CVC 3000 (pay attention to interface settings).

The advanced command set of CVC 3000 can be used for full functionality (switch by CVC 3<CR>). CVC 3000 commands which are not listed for CVC 2000 also work for CVC 2000 command set (e. g., IN_SP_).

All commands are written in capital letters with square brackets: <CR>, <CR><LF> or <LF>. Value entries are separated from command by blank and may be shortened to relevant digits (e. g., 5, 05, 005, 0005 identical for pressure presets).

The output of the controller is always with complete number of digits and leading zeros.

Set point commands are only allowed in remote mode. Whether a command has been executed correctly can be checked by IN_STAT. Via ECHO command an auto-reply of the transmitted parameter can be switched on. The set point commands REMOTE and CVC 2/3 are always possible. For safe operation send maximum 10 commands per second.

10.2.1 Pin assignment (RS232)

Sub-D panel connector

SUB-D 9 poles

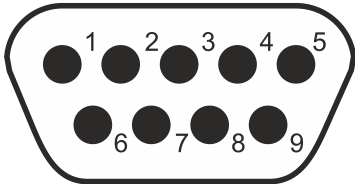

Sub-D 9 poles
(rear side of CVC 3000)

PIN	Name	Operation	PIN	Name	Operation
1	DCD	---	6	DSR	---
2	RxD	Received data	7	RTS	Transmission request
3	TxD	Transmission data	8	CTS	Ready to send
4	DTR	+10 V	9	RI	+5 V (Bluetooth, remote control)
5	GND	Mass	-	---	---

10.2.2 Read commands (CVC 2000)

Command	Operation	Reply	Description
IN_PV_1	actual pressure	XXXX mbar/hPa/Torr	unit corresponding to default settings
IN_PV_2	motor speed	XX.X Hz	actual motor speed
IN_CFG	default settings	0XXXX	VACUU·LAN
		1XXXX	continuous pumping
		2XXXX	controlling without auto mode
		3XXXX	controlling by auto mode
		4XXXX	program
		X0XXX	no coolant valve
		X1XXX	coolant valve
		XX0XX	no air admittance valve
		XX1XX	air admittance valve
		XXX0X	no automatic switch-off
		XXX1X	automatic switch-off
		XXXX0	operation by remote off
		XXXX1	operation by remote on
		IN_ERR	error status
X1XX	overpressure		
XX1X	error at vacuum sensor		
XXX1	last command at interface incorrect		
IN_STAT	state of process control	0XXX	coolant valve not triggered (closed)
		1XXX	coolant valve triggered (open)
		X0XX	air admittance valve not triggered (closed)
		X1XX	air admittance valve triggered (open)
		XX00	VACUU·LAN: inactive
		XX01	VACUU·LAN: pump down; set value > default value
		XX02	VACUU·LAN: pump down, timer running
		XX03	VACUU·LAN: stop carried out
		XX10	continuous pumping: inactive
		XX11	continuous pumping: active
		XX20	vacuum control: inactive
		XX21	vacuum control: actual pressure > set pressure
		XX22	vacuum control: actual pressure > set pressure (±1 mbar)
		XX23	vacuum control: actual pressure < set pressure
		XX30	auto mode: inaktiv
		XX31	auto mode: detect boiling point
		IN_STAT	state of process control
XX33	auto mode: automatic switch-off carried out		
XX4X	program		
XX5X	gauge mode		

10.2.3 Write commands (CVC 2000)

Command	Operation	Parameter	Description
OUT_MODE	operation mode	1	continuous pumping
		2	controls without auto mode
		3	controls by auto mode
		30	<i>optional: sensitivity: low</i>
		31	<i>optional: sensitivity: normal</i>
		32	<i>optional: sensitivity: high</i>
		4	program
OUT_SP_1	set vacuum	XXXX	unit corresponding to default settings (mbar/hPa/Torr); see respective operation for parameter range
OUT_SP_V	set vacuum plus venting*	XXXX	unit corresponding to default settings (mbar/hPa/Torr); see respective operation for parameter range
<p>* Pressure setting with venting is only possible in mode Vac control, if an air admittance valve is connected and configured, and vacuum control is started. The air admittance valve opens automatically if the actual pressure is at least 10 mbar (7.5 Torr) below the preset pressure. Venting function stops, when control is stopped by pressing START/STOP, or when mode is changed. The command OUT_SP_V must be executed anew, if necessary.</p>			
OUT_SP_2	motor speed	XX.X	motor speed in Hz (99.9 for HI)
OUT_SP_3	start-up pressure	XXXX	unit corresponding to default settings (mbar/hPa/Torr); see respective operation for parameter range
OUT_SP_4	delay time	XX:XX	hh:mm (hours:minutes)
OUT_SP_5	switch-off pressure	XXXX	unit corresponding to default settings (mbar/hPa/Torr); see respective operation for parameter range
OUT_SP_6	turn-off time	XX:XX	hh:mm (hours:minutes)
START	start process control	---	---
STOP	stop process control	1	stop process control
		2	stop process control and storing the actual pressure as default value
REMOTE	remote operation**	0	remote off
		1	remote on
<p>** For operation by remote (remote on/off), the user must ensure that no hazardous situation can arise in the system. Especially when due to activated remote direct process control is impossible.</p>			
OUT_VENT	trigger air admittance valve	0	close air admittance valve (not automatically)
		1	open air admittance valve

10.2.4 Read commands (CVC 3000)

Command	Operation	Reply	Description
IN_PV_1	actual pressure	XXXX.X (X.XEXX for Pirani) mbar/hPa/Torr	unit corresponding to default settings; with decimal place for VSK or exponentially for Pirani
IN_PV_Sx	actual pressure vacuum sensor x	XXXX.X (X.XEXX for Pirani) mbar/hPa/Torr	pressure of sensor x, unit corresponding to default settings; with decimal place for VSK or exponentially for Pirani (sequence of numeration like in display <i>Sensors</i>)
IN_PV_2	motor speed	XXX%	actual motor speed; 1-100% or <i>HI</i>
IN_PV_3	time	XX:XX h:m	process runtime (Stunden:Minuten)
IN_PV_X	pressure	XXXX.X XXXX.X ...	pressure of all connected sensors, unit corresponding to default settings (mbar/hPa/Torr)
IN_PV_T	controller uptime	XXXXdXXh	uptime in days and hours
IN_CFG	pre-settings	0XXXXXXXXXXXXXXXXX	VACUU·LAN
		1XXXXXXXXXXXXXXXXX	pump down
		2XXXXXXXXXXXXXXXXX	vac control
		3XXXXXXXXXXXXXXXXX	auto mode
		4XXXXXXXXXXXXXXXXX	program
		5XXXXXXXXXXXXXXXXX	gauge
		XyXXXXXXXXXXXXXXXXX	y: 0.....D: language* (hexadecimal)
* language: 0: German, 1: Englisch, 2: French, 3: Italian, 4: Spanish, 5: Turkish, 6: Korean, 7: Chinese, 8: Portugese, 9: Russian, A: Polish, B: Dutch, C: Japanese, D: Finnish			
IN_CFG	pre-settings	XX0XXXXXXXXXXXXXXXXX	unit mbar
		XX1XXXXXXXXXXXXXXXXX	unit Torr
		XX2XXXXXXXXXXXXXXXXX	unit hPa
		XXX0XXXXXXXXXXXXXXXXX	auto start off
		XXX1XXXXXXXXXXXXXXXXX	auto start on
		XXX0XXXXXXXXXXXXXXXXX	acoustic signal off
		XXX1XXXXXXXXXXXXXXXXX	acoustic signal on
		XXXX0XXXXXXXXXXXXXXXXX	VARIO pump not connected
		XXXX1XXXXXXXXXXXXXXXXX	VARIO pump connected
		XXXX0XXXXXXXXXXXXXXXXX	VMS not connected
		XXXX1XXXXXXXXXXXXXXXXX	VMS connected
		XXXX0XXXXXXXXXXXXXXXXX	in-line valve not connected
		XXXX1XXXXXXXXXXXXXXXXX	in-line valve connected
		XXXX0XXXXXXXXXXXXXXXXX	coolant valve not connected

Command	Operation	Reply	Description
IN_CFG	pre-settings	XXXXXXXX1XXXXXX	coolant valve connected
		XXXXXXXXX0XXXXXX	air admittance valve not connected
		XXXXXXXXX1XXXXXX	air admittance valve connected
		XXXXXXXXX0XXXXXX	fault indicator not connected
		XXXXXXXXX1XXXXXX	fault indicator connected
		XXXXXXXXX0XXXXXX	level sensor not connected
		XXXXXXXXX1XXXXXX	level sensor connected
		XXXXXXXXX0XXXXXX	remote module not connected
		XXXXXXXXX1XXXXXX	remote module connected
		XXXXXXXXXXyXX	y: 1.....9: sensor number (active sensor)
		XXXXXXXXXXyX	y: 1.....9: sensor quantity
		XXXXXXXXXX0	no operation by remote
		XXXXXXXXXX1	operation by remote
		IN_STAT	process control status
1XXXXX	pump on		
X0XXXX	in-line valve closed		
X1XXXX	in-line valve open		
XX0XXX	coolant valve closed		
XX1XXX	coolant valve open		
XXX0XX	air admittance valve closed		
XXX1XX	air admittance valve open		
XXXX0X	VACUU·LAN		
XXXX1X	pump down		
XXXX2X	vac control		
XXXX3X	auto mode		
XXXX4X	program		
XXXX5X	gauge		
XXXXX0	control off		
XXXXX1	pump down - find boiling point		
XXXXX2	set vacuum reached - boiling point found		
XXXXX3	below set vacuum - automatic switch-off		
IN_ERR	error status		
		1XXXXXXXXX	pump error
		X0XXXXXXXXX	no in-line valve error
		X1XXXXXXXXX	in-line valve error
		XX0XXXXXXXXX	no coolant valve error
		XX1XXXXXXXXX	coolant valve error
		XXX0XXXXXX	no air admittance valve error
		XXX1XXXXXX	air admittance valve error
		XXXX0XXXXX	no overpressure

Command	Operation	Reply	Description
IN_ERR	error status	XXXX1XXXX	overpressure
		XXXXXX0XXX	no level sensor error
		XXXXXX1XXX	level sensor error
		XXXXXX0XX	no external error
		XXXXXX1XX	external error
		XXXXXXX0X	catch pot not full
		XXXXXXX1X	catch pot full
		XXXXXXXXX0	last interface command correct
		XXXXXXXXX1	last interface command incorrect
IN_SP_1	set vacuum	XXXX mbar/hPa/Torr	unit corresponding to default settings
IN_SP_2	maximum motor speed	XXX%	motor speed in % (1-100% or <i>HI</i>)
IN_SP_3	start-up pressure	XXXX mbar/hPa/Torr	unit corresponding to default settings, start-up pressure for VACUU·LAN or two-point control
IN_SP_4	delay time	XX:XX h:m	hours:minutes (00:00 = off)
IN_SP_5	switch-off pressure	XXXX mbar/hPa/Torr	maximum for vac control, minimum for pump down unit corresponding to default settings
IN_SP_6	runtime	XX:XX h:m	hours:minutes; preset process time
IN_SP_P1y	time	XX:XX:XX h:m:s	hours:minutes:seconds time in program step y (0.....9)
IN_SP_P2y	pressure	XXXX mbar/hPa/Torr	pressure in program step y (0.....9) unit corresponding to default settings
IN_SP_P3y	air admittance valve	0	no air admittance valve in program step y (0.....9)
		1	air admittance valve in program step y (0.....9)
IN_SP_P4y	step	0	no step in program step y (0.....9)
		1	step in program step y (0.....9)
IN_SP_P5y	auto	0	no auto in program step y (0.....9)
		1	auto in program step y (0.....9)
IN_VER	version	CVC 3000 VX.XX	software version

10.2.5 Write commands (CVC 3000)

Command	Operation	Parameter	Description
OUT_MODE	operation mode	0	VACUU·LAN
		1	continuous pumping
		2	vac control
		3	auto mode
		30	<i>optional: sensitivity: low</i>
		31	<i>optional: sensitivity: normal</i>
		32	<i>optional: sensitivity: high</i>
		4	program
OUT_CFG	restart searching Vacuubus device	yXXX	y: 0.....D: language+ (hexadecimal), see: read command CVC 3000: IN_CFG
		X0XX	unit mbar
		X1XX	unit Torr
		X2XX	unit hPa
		XX0X	auto start off
		XX1X	auto start on
		XXX0	beep off
		XXX1	beep on
		XXXX0	internal air admittance valve off
		XXXX1	internal air admittance valve auto
XXXX2	internal air admittance valve on		
OUT_SP_1	set vacuum	XXXX	unit corresponding to default settings (mbar/hPa/Torr); see respective operation for parameter range
OUT_SP_V	set vacuum with venting	XXXX	unit corresponding to default settings (mbar/hPa/Torr); see respective operation for parameter range
OUT_SP_2	motor speed	XXX	motor speed in % (1-100%) or <i>HI</i> or 101 allowed
OUT_SP_3	start-up pressure	XXXX	unit corresponding to default settings (mbar/hPa/Torr); see respective operation for parameter range
OUT_SP_4	delay time	XX:XX	hh:mm (hours:minutes)
OUT_SP_5	switch-off pressure	XXXX	unit corresponding to default settings (mbar/hPa/Torr); see respective operation for parameter range
OUT_SP_6	switch-off time	XX:XX	hh:mm (hours:minutes)
OUT_SP_PL	open program	X	program 0.....9
OUT_SP_PS	store program	X	program 0.....9
OUT_SP_P1y	time	XX:XX:XX oder +XX:XX:XX	total runtime until program step y (0.....9) or time for program step y (0.....9) (additive)
OUT_SP_P2y	pressure	XXXX	pressure in program step y (0.....9) ; unit corresponding to default settings (mbar/hPa/Torr)
OUT_SP_P3y	air admittance valve	0	no air admittance valve in program step y (0...9)
		1	air admittance valve in program step y (0.....9)

Command	Operation	Parameter	Description
OUT_SP_P4y	step	0	no Step in program step y (0.....9)
		1	Step in program step y (0.....9)
OUT_SP_P5y	auto	0	no Auto in program step y (0.....9)
		1	Auto in program step y (0.....9)
		2	Auto in program step y (0.....9)
START	---	1	start process control
STOP	---	0	stop and delete error
		1	stop
		2	stop and store set vacuum
REMOTE**	remote operation	0	remote off
		1	remote on
** For operation by remote (remote on/off), the user must ensure that no hazardous situation can arise in the system. Especially when due to activated remote direct process control is impossible.			
ECHO***		0	echo off
		1	echo on, write commands with reply value
*** With command ECHO 1 a return value can be activated at write commands. A return value is only given if the command is performed correctly.			
CVC	---	2	CVC 2000 commands
		3	CVC 3000 commands****
**** After being switched on, the controller is in CVC 2 mode by default. Send CVC 3 and STORE to permanently set the controller RS 232C commands to the extended set CVC 3000.			
OUT_VENT	---	0	air admittance valve closed
		1	air admittance valve open
		2	venting until atmospheric pressure (1060 mbar at maximum)
STORE	store settings		store settings permanently, if „ECHO = 1“ after realization
OUT_SENSOR	---	1	internal sensor, if connected; alternatively external sensor.
		2...9	external sensors (if connected)

10.3 Ordering information

Ordering information CVC	Vacuum controller	Order-N°
	CVC 3000 table top version	683160
	CVC 3000 built-in version	636595
	CVC 3000 + VSP 3000 (package for fine vacuum control)	635983

Ordering information spare parts	Spare parts	Order-N°
	Vacuum sensor (vacuum gauge head)	
	VSK 3000, 1080-0,1 mbar	636657
	VSP 3000 (Pirani), $1 \times 10^3 - 1 \times 10^{-3}$ mbar	636163
	VACUU·VIEW, Vacuum gauge with integrated vacuum sensor, 1100-0.1 mbar	683220
	VACUU·VIEW extended, Vacuum gauge with integrated vacuum sensor, 1100-0.001 mbar	683210
	In-line isolation valve (electromagnetic vacuum valve)	
	VV-B 6, 24 VDC, VACUU·BUS	674290
	VV-B 6C, 24 VDC, VACUU·BUS	674291
	VV-B 15C, KF 16, VACUU·BUS	674210
	VV-B 15C, KF 25, VACUU·BUS	674215
	Coolant valve VKW-B, VACUU·BUS	674220
	Air admittance valve VBM-B / KF 16, VACUU·BUS	674217
	Y adapter VACUU·BUS	636656
	Extension cable VACUU·BUS, 2m	612552
	Wall duct VACUU·BUS	636153
	Cable RS 232C, 9-poles, Sub-D	637837
	Installation kit CVC 3000 (spring clips + screws)	636593
	Level sensor (for round bottom flask 500 ml)	699908
	Digital I/O interface module VACUU·BUS	636228
	Analog I/O interface module VACUU·BUS	636229
	Analog I/O interface module 4–20mA/0–10V VACUU·BUS	635425
	Vacuum management module VMS-B, 100-230 V, 3.5 A, CEE	676030

Ordering information VACUU·CONTROL®	Remote control	Order-N°
	VACUU·CONTROL® WLAN version	683110
	VACUU·CONTROL® LAN version	683120

Ordering information accessories	Accessories	Order-N°
	Selection knob	612091
	Plug-in rubber foot	638901
	Spring clip	636782
	Wall plug power supply 30W 24V; interchangeable mains plugs	612090
	Hose nozzle	636045
	Hose	636046
	Locking ring 10 mm for knurled nut M14 x 1 (637657)	637658
	Round head screw 4 x 18	636947
	O-ring 28 mm x 2 mm	636975
	Knurled nut M14 x 1 for hose fitting DN ^x 10/8mm, without locking ring	637657

^x conversion - example: $d_i = 10 \text{ mm} = \text{DN } 10$

Source of supply

International sales offices and specialized trade

Purchase original accessories and spare parts from your specialized distributor or through international sales offices of **VACUUBRAND GMBH + CO KG**.



- ⇒ Information about the complete product range are available in the current [product catalog](#).
- ⇒ For orders, questions about vacuum control and optimal accessories, please contact your specialized distributor or an [international sales office](#) of **VACUUBRAND GMBH + CO KG**.

10.4 Service

Service range Take advantage of the comprehensive service range of **VACUUBRAND GMBH + CO KG**.



Service in detail

- Product guidance and practical solutions,
- fast delivery of spare parts and accessories,
- professional maintenance,
- immediate repairs processing,
- service on the spot (available upon request),
- [calibration](#) (DAkkS accredited),
- return, disposal.

⇒ For further information visit our website:
www.vacuubrand.com.

Service handling

Meet the terms of
service

1. Contact your local dealer or our service department¹.
2. Request a RMA number for your order.
3. Clean your product thoroughly and if necessary decontaminate it professionally.
4. Please fill in the form [Health and Safety Clearance](#) completely
5. Return your product including:
 - RMA number,
 - repair order,
 - form ***Health and Safety Clearance***,
 - short error description.

Send in your product
(return)



- ⇒ Reduce downtime, speed up the handling. Keep the required data and documents ready when contacting the service department.
- ▶ Your order can be quickly and easily processed.
 - ▶ Hazards can be excluded.
 - ▶ A short description or photos may help for error location.

¹ -> Phone: +49 9342 808-5660, Fax: +49 9342 808-5555,
 Mail to: service@vacuubrand.com

Clearance certificate

Health and safety clearance form



Devices will not be accepted for any handling before we have received this declaration.
Please read and comply with "Notes on return to the factory".
Oil filled pumps: Drain oil prior to shipping absolutely!

1. Device (Model): 2. Serial no.:
3. Reason for return / malfunction:

4. Has the device been used in a copper process step (e.g., semiconductor production). yes no

5. Substances (gases, liquids, solids) in contact with the device / which have been pumped:

6. Prior to return to the factory the device has been decontaminated. yes no
Description of the decontamination method and the test / verification procedure:

7. The device is free of hazardous, harmful substances. yes no

8. Protective measures required for VACUUBRAND employees:

9. If the paint is damaged, we wish a repaint or a replacement of parts for reason of appearance (repaint and replacement at customer's expense). yes no

10. Legally binding declaration

We assure for the returned device that all substances, which have been in contact with the device are listed in section 5 and that the information is complete and that we have not withheld any information. We declare that all measures - where applicable - have been taken listed in section "Return to the factory". By our signature below, we acknowledge that we accept liability for any damage caused by providing incomplete or incorrect information and that we shall indemnify VACUUBRAND from any claims as regards damages from third parties. We are aware that as expressed in § 823 BGB (Public Law Code of Germany) we are directly liable for injuries or damages suffered by third parties, particularly VACUUBRAND employees occupied with handling/repairing the product.
Shipping of the device must take place according to regulations.

Name: Signature:

Job title: Company's seal:

Date:

Release for repair grant by VACUUBRAND (date / signature):

10.5 Glossary

- HI mode** scores maximum pumping speed and low ultimate vacuum with the pump and optimum speed for the respective pressure (automatic speed reduction at ultimate vacuum).
- Hysteresis** Regulates control performance of 2-point control in mode Vac control and Program. The hysteresis determines the threshold to which the actual value may differ from the setpoint. A too small hysteresis value leads to a frequent switching cycle. A too large hysteresis value leads to imprecise vacuum control.
- Peltronic®** Electronic emission condenser; the Peltronic® condenses solvent vapors without external coolant such as water or dry ice. Cooling is achieved by Peltier elements. All wetted materials are highly resistant against chemicals.
- Periphery equipment** in this manual: accessories and apparatus connected to the vacuum system such as vacuum valves, vacuum pumps and recipients; see also chapter **4.2.3 VACUU-BUS®**.
- Quick adaption** during running operation an operation mode can be tuned without calling up the corresponding operation menu. Usable for the modes *Vac control – set vacuum adaption* and *Pump down – VARIO® motor speed adaption*.
- VACUU-BUS** digital communication system of **VACUUBRAND**. Possible components are: pressure/vacuum sensors, valves, level sensors, I/O modules; **VARIO®** pumps. When connecting several VACUU-BUS components of the same type it is necessary to regard that these components require different address numbers for communication; → see also **Address assignment (configuration) on page 83**.
- VACUU-CONTROL®** web-based remote control enables the monitoring and control of vacuum pumping units via computers or mobile devices such as Smartphones. With the new LAN or WLAN adapter all pumping units and vacuum systems equipped with the CVC 3000 vacuum controller or a DCP 3000 vacuum gauge can be integrated into a computer network.
- VMS-B module** The Vacuum-Management-System module VMS-B switches a vacuum pump according to actual demand from one or two applications. It is operated by one or two vacuum controllers CVC 3000. If two CVC 3000 are connected to the VMS-B it switches off the pump only if both applications do not need a vacuum supply anymore

10.6 Index

A		D		K	
Abbreviations	11	Defaults (standard)	76	Key combinations	35
Action step	10	Differential pressure	87	L	
Active reset	94	Differential pressure measurement	87	Load Default	95
Adapt set vacuum	53	Digitale Druckanzeige	89	Load factory settings	95
Additional icons	10	digital pressure gauge	36	M	
Additional notes	9	Direct installation	25	Menu – Auto mode	58
Address assignment	83	Display graphic (curve)	51	Menu display in general	40
Address table VACUU·BUS	86	Display icons	37	menu items (Configuration)	76
Adjustment at atmospheric pressure	98	E		menu items (Function)	81
Adjustment at reference pressure	100	EC Declaration of Conformity	121	Menu – Program	59
Adjustment under vacuum	99	Edit program	62	Menu – Pump down	56
Analog I/O module	86	Electrical connection	28	Menu – Vac control	57
Assigned address numbers	83	Environmental protection	19	Menu VACUULAN	60
ATEX approval	17	Error display	39,88	Mode	45
ATEX category	17	EU-Konformitätserklärung	121	Mode menu	46
ATEX VARIO pump	86	Examples of use	26	Momentarily venting	48
Audio signal (beep)	39	Explosion danger	15	Motor speed	54
Automatic reset	94	explosive mixtures	15	N	
Auto mode	46	F		Navigation	41
Auto start function	76	Fault – Cause – Remedy	90	O	
B		Fault indication	39	Open/Change program	61
Back (return)	42	fine vacuum control	102	Operating elements	34
Bar graphic	36	Firmware update	82	Operation	41,43
bar marking	41	First steps	6	Operation menus	55
bench-top type	24	First steps on delivery status	6	Operation modes	23
built-in version	25	Foreseeable misuse	13	optimize vacuum control	27
C		Functionality	22	Optimizing operation mode	55
Call-up mode menu	45	Function menu	80	Ordering information	113
Change operation mode	49	G		P	
Cleaning and maintenance	97	Goods arrival	20	Particles, liquids, dust	16
Clearance certificate	116	H		Peripherals	11
Condensate	16	Handling	41	Pin assignment (RS232)	105
configuration	83	Handling CVC 3000	41	Possible address configurations	86
Configuration menu	75	Health and Safety Clearance	18	Power supply	28
Connection examples	31	Hysteresis	58,59	Prepare sensors	87
Connect vacuum line	30	I		Pressure display	36
Contact	8	Improper use	12,13	Pressure history	51
Content selection	81	Included materials	20	Product comparison	103
Continuous venting	48	Initialize frequency converter	81	Product description	20
Control panel keys	34	Input (data entry)	42	Program	46
Copyright	7	Installation	24	Program display at operation	69
Creating a new program	65	Installation conditions	24	program editor	62
CVC 2000	106	int. Air V.	81	Program examples	72
CVC 3000	11	Intended use	12	Program functions	61
		Interface	11	Program memory	70
		interface commands	105	Protective clothing	15
		Internal air admittance valve	81	Pump down	46

Q		T	
Quality standards	15	Table top version	24
R		Target groups	14
Rating plate	104	Technical data	101
Read command	106	Technical information	101
Reference sensors	78	Technical support	88
Remote	79	temporary buffer	70
Requirements for services	18	Term definition	11
Reset	94	U	
Residual energy	16	US/CAN Certificate	122
Responsibility Assignment Matrix	14	User permissions	14
RMA-N°	19	V	
RMA number	115	Vac control	46
RS-232	79	VACUU·BUS	32
RS232 port	39	VACUU·BUS accessories	33
S		VACUU·BUS components	33
Safety and service	18	VACUU·BUS principle	32
safety instructions	12	VACUU·CONTROL	16
Safety symbols	9	VACUULAN	46,60
sales offices	114	Vacuum connection	30
Sample form	74	Vacuum controller CVC 3000	20
Scope of supply	20	vacuum port	30
Selection	41	VACUU·VIEW	33,113
Selection knob	34	VACUU·VIEW extended	33,113
Select language	44	Vario init	81
Select language and units	6	Venting (VENT)	47
Select operation mode	45	W	
Select pressure unit	44	Warning levels	8
Sensor adjustment	77	Warning triangle	88
Sensor readjustment	98	Wetted parts	104
Sensor selection	78	Write command	111
Service	115		
shortcuts	35		
Signal sounds	39		
Specification and features	22		
Specified content	76,81		
Start controlling	47		
Start Regelung	47		
Store program	68		
Sub-D	21		
Sub-D Einbaustecker	105		
Submenu Configuration	40		
Submenu Display	77		
Submenu RS232	79		
Submenus	41		
Submenu Sensors	78		
Submenu Vacuubus	83		
Switch-on CVC 3000	43		
Switch-on/-off	43		

10.7 Certifications

10.7.1 EC Declaration of Conformity

EU-Konformitätserklärung
EC Declaration of Conformity
Déclaration CE de conformité



Hersteller / Manufacturer / Fabricant:

VACUUBRAND GMBH + CO KG · Alfred-Zippe-Str. 4 · 97877 Wertheim · Germany

Hiermit erklärt der Hersteller, dass das Gerät konform ist mit den Bestimmungen der Richtlinien:

Hereby the manufacturer declares that the device is in conformity with the directives:

Par la présente, le fabricant déclare, que le dispositif est conforme aux directives:

2004/108/EG (EMV), 2006/95/EG (NRL), 94/9/EG (ATEX) – gültig bis / valid until / valable jusqu'au 19.04.2016.

2014/30/EU (EMV), 2014/35/EU (NRL), 2014/34/EU (ATEX) – gültig ab / valid from / valable à partir du 20.04.2016.

Vakuu-Controller / Vacuum controller / Régulateur de vide

Typ / Type / Type: **CVC 3000**

Artikelnummer / Order number / Numéro d'article: 683160, 699916

Seriennummer / Serial number / Numéro de série: Siehe Typenschild / See rating plate / Voir plaque signalétique

Angewandte harmonisierte Normen / Harmonized standards applied / Normes harmonisées utilisées:

DIN EN 12100:2011, DIN EN 61326-1:2013, IEC 61010-1:2010 (Ed. 3) / DIN EN 61010-1:2011,

DIN EN 1127-1:2011, DIN EN 13463-1:2009

Bevollmächtigter für die Zusammenstellung der technischen Unterlagen / Person authorised to compile the technical file / Personne autorisée à constituer le dossier technique:

Dr. J. Dirscherl · VACUUBRAND GMBH + CO KG · Alfred-Zippe-Str. 4 · 97877 Wertheim · Germany

Ort, Datum / place, date / lieu, date: Wertheim, 03.03.2016



(Dr. F. Gitmans)

*Geschäftsführer / Managing director /
Gérant*

ppa. 

(Dr. J. Dirscherl)

*Technischer Leiter / Technical Director /
Directeur technique*

VACUUBRAND GMBH + CO KG

Alfred-Zippe-Str. 4
97877 Wertheim



Tel.: +49 9342 808-0

Fax: +49 9342 808-5555

E-Mail: info@vacuubrand.com

Web: www.vacuubrand.com

10.7.2 US/CAN Certificate

<h1>Certificate</h1>		
Certificate no.		CU 72091199 01
License Holder: VACUUBRAND GMBH + Co. KG Alfred-Zippe-Str. 4 97877 Wertheim Germany	Manufacturing Plant: VACUUBRAND GMBH + Co. KG Alfred-Zippe-Str. 4 97877 Wertheim Germany	
Test report no.: USA-DS 30981596 001	Client Reference: M. von Przychowski	
Tested to: UL 61010-1:2004 R10.08 CAN/CSA-C22.2 61010-1:2004		
Certified Product: Measurement and Control Device for Vacuum	License Fee - Units	
Model Designation: Main Unit: 1) CVC 3000, CVC 3000E, CVC 3000E ARB C3, DCP 3000, DCP 3000E Valves and Sensors: 2) VKW-B, 3) VB M-B, 4) Liquid level sensor (699908), 5) VV-B 6, 6) VV-B 6C, 7) VV-B 15C, 8) VSK 3000		7
Rated Voltage DC: 1-3) 24V; 4) 8-30V; 5-7) 24V; 8) 6-30V Rated Current: 1) 1.25A; 4) 5mA (max.); 8) 5mA Rated Power: 1) 3.4W; 2) 2W; 3) 4W; 5) 8W; 6) 5.5W; 7) 12W Protection Class: III		7
Appendix: 1		
Licensed Test mark: 	Signature  Dipl.-Ing. M. Glagla QA Certification Officer	Date of Issue (day/mo/yr) 17/06/2009
<small>TÜV Rheinland of North America, Inc., 12 Commerce Road, Newtown, CT 06456, Tel. (203) 426-9888 Fax (203) 426-4009</small>		



Technology for Vacuum Systems

Manufacturer:

VACUUBRAND GMBH + CO KG
Alfred-Zippe-Str. 4
97877 Wertheim
GERMANY

Phone:

- Head office +49 9342 808-0
- Sales +49 9342 808-5550
- Service +49 9342 808-5660

Fax: +49 9342 808-5555

E-Mail: info@vacuubrand.com

Web: www.vacuubrand.com

© VACUUBRAND GMBH + CO KG – 2016

Version : 999151_EN_CVC3000_ONLINE TDD2/V1.0 (03.03.2016)

